



# CY84

## ROTARY MOWER

Published 03/08

Part NO. 00771528C

# OPERATOR'S MANUAL



This Operator's Manual is an integral part of the safe operation of this machine and must be maintained with the unit at all times. READ, UNDERSTAND, and FOLLOW the Safety and Operation Instructions contained in this manual before operating the equipment. *C01-Cover*

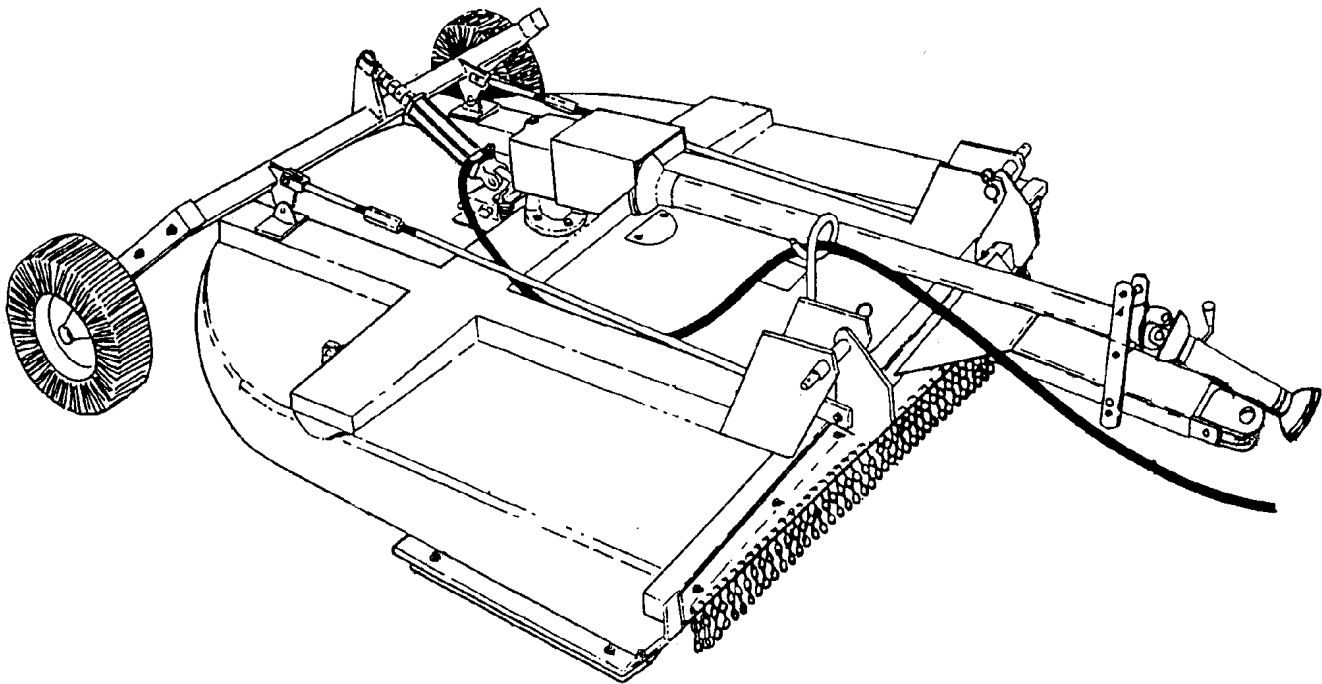

FC-0002

## RHINO<sup>®</sup>

1020 S. Sangamon Ave.  
Gibson City, IL 60936  
800-446-5158  
Email: [parts@servis-rhino.com](mailto:parts@servis-rhino.com)

**¡ATENCIÓN!**

LEA EL INSTRUCTIVO



Si No Lee Ingles, Pida  
Ayuda a Alguien  
Que Se Lo Lea Para Que le  
Traduzca Las  
Medidas de Seguridad

**A<sup>®</sup> MEMBER OF THE  
ALAMO GROUP**  
ALWAYS ON THE CUTTING EDGE<sup>®</sup>

© 2008 Alamo Group Inc.

\$0.00

# To the Owner/Operator/Dealer

All implements with moving parts are potentially hazardous. There is no substitute for a cautious, safe-minded operator who recognizes the potential hazards and follows reasonable safety practices. The manufacturer has designed this implement to be used with all its safety equipment properly attached to minimize the chance of accidents.

**BEFORE YOU START!** Read the safety messages on the implement and shown in your manual. Observe the rules of safety and common sense!

| <b>! DANGER</b>  |   |  |   |
|--|---|--|---|
| <b>FAILING TO FOLLOW SAFETY MESSAGES AND OPERATING INSTRUCTIONS CAN CAUSE SERIOUS BODILY INJURY OR EVEN DEATH TO OPERATOR AND OTHERS IN THE AREA.</b>  |   |  |   |
| <b>1.</b><br>   | <b>2. NO RIDERS. NO CHILDREN OPERATORS.</b><br>    | <b>3. USE SAFETY SHOES, HARD HAT, SAFETY GLASSES, SEAT BELTS, &amp; ROPS</b><br> | <b>4. BLOCK UP SECURELY BEFORE WORKING UNDER.</b><br>  |
| <p>1. Study and understand operator's manual, safety signs, and Instructional decals for tractor and implement to prevent misuse, abuse, and accidents.</p> <ul style="list-style-type: none"> <li>● Learn how to stop engine suddenly in an emergency. Be alert for passerby and especially children.</li> </ul> <p>2. Allow no children on or near implement or tractor. Allow no riders on tractor and implement. Falling off may cause serious injury or death from being run over by tractor or cutter or contact with rotating blades.</p> <p>3. Operate only with tractor having Roll-Over Protective Structure (ROPS) and with seatbelt fastened securely and snugly to prevent injury and possible death from falling off or tractor overturn. Personal Protective Equipment such as Hard Hat, Safety Glasses, Safety Shoes, and Ear Plugs are Recommended.</p> <p>4. Block up or support raised machine and all lifted components securely before putting hands or feet under or working underneath any lifted components to prevent crushing injury or death from sudden dropping or inadvertent operation of controls. Make certain area is clear before lowering or folding.</p> <p>5. Before transporting, put Lift Lever in detent or full-lift position. Secure the implement for transport by installing Cylinder Stops or Transport Pin on Pull-type implement center axle and Wing Transport Locks on folding implements.</p> <ul style="list-style-type: none"> <li>● Attach Safety Chain to cutter and towing unit securely. See Operator's Manual.</li> </ul> <p>6. Make certain that the SMV sign, Warning Lights, and Reflectors are clearly visible. Follow local traffic codes.</p> <p>7. Never operate with Cutting Head raised if passerby, bystanders, or traffic are in the area to reduce possibility of injury or death from Objects thrown by Blades under Guard or cutter structure.</p> <p>8. Before dismounting, secure implement in transport position or lower to ground.</p> <ul style="list-style-type: none"> <li>● Put tractor in park or set the brake, disengage PTO, stop engine, and remove key, and wait until noise of rotation has ceased to prevent entanglement in rotating parts which can cause injury or death.</li> <li>● Never mount or dismount a moving vehicle. Crushing from runover may cause injury or death.</li> </ul> |   |  |   |
| <b>5. TRANSPORT SAFELY, LOCK UP.</b><br>  | <b>6. USE SMV, LIGHTS, &amp; REFLECTORS.</b><br> | <b>7. DO NOT OPERATE WITH CUTTER OR WING RAISED.</b><br>                       | <b>8. DO NOT MOUNT OR DISMOUNT WHILE MOVING.</b><br> |
| 00749117   |   |  |   |

## WARRANTY INFORMATION:

Read and understand the complete Warranty Statement found in this Manual. Fill out the Warranty Registration Form in full and return it to within 30 Days. Make certain the Serial Number of the Machine is recorded on the Warranty Card and on the Warranty Form that you retain

➤ **BE SAFE!**

➤ **BE ALERT!**

➤ **BE ALIVE!**

➤ **BE TRAINED  
before operating  
the Mower!**

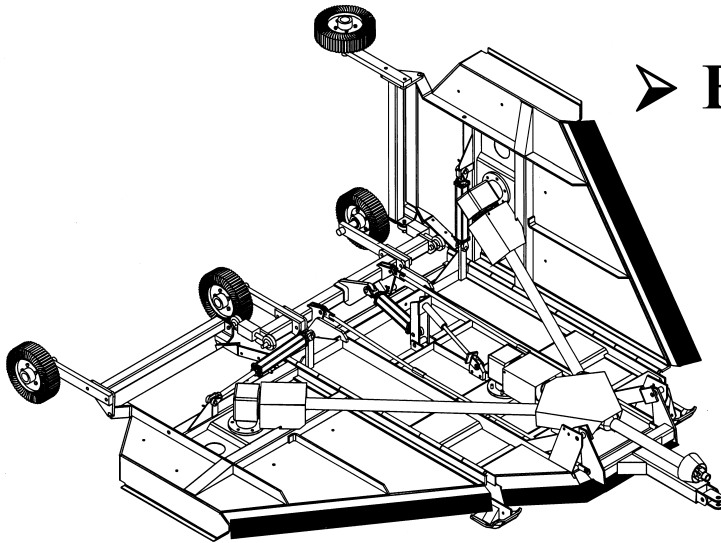

**M&W**



*Safety Training  
Makes the Difference*

In order to reduce accidents and enhance the safe operation of mowers, *Alamo Group Ag Division*, in cooperation with other industry manufacturers has developed the AEM/FEMA Industrial and Agricultural Mower Safety Practices video and guide book.

The video will familiarize and instruct mower-tractor operators in safe practices when using industrial and agricultural mowing equipment. It is important that Every Mower Operator be educated in the operation of their mowing equipment and be able to recognize the potential hazards that can occur while operating a mower. This video, along with the mower operator's manual and the warning messages on the mower, will significantly assist in this important education.

Your Authorized *Alamo Ag Dealer* may have shown this video and presented you a DVD Video when you purchased your mower. If you or any mower operator have not seen this video, **Watch the Video, Read this Operator's Manual, and Complete the Video Guidebook** before operating your new mower. If you do not understand any of the instructions included in the video or operator's manual or if you have any questions concerning safety of operation, contact your supervisor, dealer or *Alamo Group Ag*.

If you would like a VHS video tape of the video, please e-mail [AEMVideo@alamo-group.com](mailto:AEMVideo@alamo-group.com) or Fax AEM VHS Video at (830) 372-9529 or mail in a completed copy of the form on the back of this page to AEM VHS Video 1502 E Walnut Street, Seguin, TX 78155. and request the VHS video version. Please include your name, mailing address, mower model and serial number.

Every operator should be trained for each piece of equipment (Tractor and Mower), understand the intended use, and the potential hazards before operating the equipment.

**Alamo Group Ag. Division is willing to provide  
one (1) AEM Mower Safety Practices Video**

- Please Send Me:  VHS Format – AEM/FEMA Mower Operator Safety Video  
 DVD Format – AEM/FEMA Mower Operator Safety Video  
 Mower Operator’s Manual  
 AEM Mower Operator’s Safety Manual

Requester Name \_\_\_\_\_ Phone: \_\_\_\_\_

Requester Address: \_\_\_\_\_

City \_\_\_\_\_

State \_\_\_\_\_

Zip Code \_\_\_\_\_

Mower Model: \_\_\_\_\_ Serial Number: \_\_\_\_\_

Date Purchased: \_\_\_\_\_ Dealer Salesperson: \_\_\_\_\_

Dealership Name: \_\_\_\_\_ Dealership Location: \_\_\_\_\_

Mail to:

AEM Video Services

1502 E Walnut street

Seguin, TX 78155

Or Fax to:

(830) 372-9529

Or E-mail to:

AEMVideo@alamo-group.com

# TABLE OF CONTENTS

|  |            |
|--|------------|
| <b>SAFETY SECTION .....</b>                          | <b>1-1</b> |
| Safety Messages .....                                | 1-2        |
| Decal Location .....                                 | 1-12       |
| Decal Description .....                              | 1-16       |
| Federal Laws and Regulations .....                   | 1-23       |
| <b>INTRODUCTION SECTION.....</b>                     | <b>2-1</b> |
| Attention Owner/Operator .....                       | 2-4        |
| <b>ASSEMBLY SECTION .....</b>                        | <b>3-1</b> |
| Optional A-Frame Assembly .....                      | 3-2        |
| Single Tail Wheel Assembly - Lift-Type .....         | 3-2        |
| Dual Tail Wheel Assembly .....                       | 3-3        |
| Tongue .....   | 3-3        |
| Axle .....   | 3-4        |
| Control Rods .....                                   | 3-4        |
| Hydraulic or Manual Lift .....                       | 3-5        |
| Wheels .....   | 3-5        |
| Shields, Guards, and Deflectors .....                | 3-6        |
| Chain Guard (Extra Equipment).....                   | 3-7        |
| Driveline Attachment.....                            | 3-8        |
| Gearbox Shield Assembly.....                         | 3-8        |
| Check Chains (Extra Equipment) for Lift-Models ..... | 3-9        |
| Jackshaft Bearing Support Assembly .....             | 3-10       |
| <b>OPERATION SECTION .....</b>                       | <b>4-1</b> |
| Standard Equipment and Specifications .....          | 4-3        |
| OPERATOR REQUIREMENTS .....                          | 4-4        |
| TRACTOR REQUIREMENTS .....                           | 4-5        |
| ROPS and Seat Belt .....                             | 4-5        |
| Tractor Safety Devices .....                         | 4-5        |
| 3-Point Hitch .....                                  | 4-6        |
| Front End Weight .....                               | 4-7        |
| Power Take Off (PTO) .....                           | 4-7        |
| GETTING ON AND OFF THE TRACTOR .....                 | 4-8        |
| Boarding the Tractor .....                           | 4-8        |
| Dismounting the Tractor.....                         | 4-9        |
| STARTING THE TRACTOR .....                           | 4-10       |
| CONNECTING THE MOWER TO THE TRACTOR .....            | 4-10       |
| Connecting the Mower - Lift-Type .....               | 4-11       |
| Connecting the Mower - Pull-Type.....                | 4-12       |
| SETTING THE MOWER .....                              | 4-13       |
| Setting Mower Height - Lift-Type .....               | 4-13       |
| Setting Mowing Height - Pull-Type.....               | 4-14       |
| Setting Deck Pitch.....                              | 4-15       |
| DRIVELINE ATTACHMENT .....                           | 4-15       |
| Driveline Length Check.....                          | 4-16       |
| PRE-OPERATION INSPECTION AND SERVICE .....           | 4-17       |

|  |      |
|--|------|
| Tractor Pre-Operation Inspection/Service ..... | 4-18 |
| Mower Pre-Operation Inspection/Service .....   | 4-18 |
| Cutting Component Inspection .....             | 4-21 |
| Blade Bolt Inspection .....                    | 4-22 |
| DRIVING THE TRACTOR AND IMPLEMENT .....        | 4-25 |
| Starting the Tractor .....                     | 4-26 |
| Brake and Differential Lock Setting .....      | 4-26 |
| Raising the Mower .....                        | 4-27 |
| Driving the Tractor and Mower .....            | 4-27 |
| Crossing Ditches and Steep Inclines .....      | 4-28 |
| OPERATING THE TRACTOR AND IMPLEMENT .....      | 4-29 |
| Foreign Debris Hazards .....                   | 4-30 |
| Bystanders/Passersby Precautions .....         | 4-30 |
| Engaging the Power Take Off (PTO) .....        | 4-31 |
| PTO RPM and Ground Speed .....                 | 4-32 |
| Operating the Mower .....                      | 4-32 |
| Shutting Down the Implement .....              | 4-36 |
| DISCONNECTING THE MOWER FROM THE TRACTOR ..... | 4-36 |
| MOWER STORAGE .....                            | 4-38 |
| TRANSPORTING THE TRACTOR AND IMPLEMENT .....   | 4-38 |
| Transporting on Public Roadways .....          | 4-39 |
| Hauling the Tractor and Implement .....        | 4-41 |
| TROUBLESHOOTING GUIDE .....                    | 4-43 |

## **MAINTENANCE SECTION .....** **5-1**

|  |     |
|--|-----|
| Lubrication .....                              | 5-2 |
| Gearbox Lubrication .....                      | 5-3 |
| Tail Wheel Lubrication .....                   | 5-3 |
| Driveline Lubrication .....                    | 5-4 |
| Driveline Shield - Pull-Type .....             | 5-4 |
| Protective, Integral Shields - Lift-Type ..... | 5-5 |
| Slip Clutch .....                              | 5-6 |
| Seasonal Slip Clutch Maintenance .....         | 5-6 |
| Blade Servicing .....                          | 5-7 |
| Blade Sharpening .....                         | 5-7 |
| Blade Removal .....                            | 5-8 |
| Blade Carrier Removal .....                    | 5-8 |
| Blade Carrier Installation .....               | 5-8 |
| Storage .....                                  | 5-9 |
| Proper Torque For Fasteners .....              | 5-9 |

# **SAFETY SECTION**

Safety Section 1-1

# SAFETY

## Safety Messages

A careful operator is the best operator. Safety is of primary importance to the manufacturer and should be to the owner/operator. Most accidents can be avoided by being aware of your equipment, your surroundings, and observing certain precautions. The first section of this manual includes a list of Safety Messages that, if followed, will help protect the operator and bystanders from injury or death. Read and understand these Safety Messages before assembling, operating or servicing this Implement. This equipment should only be operated by those persons who have read the Manual, who are responsible and trained, and who know how to do so responsibly.



The Safety Alert Symbol combined with a Signal Word, as seen below, is used throughout this manual and on decals which are attached to the equipment. The Safety Alert Symbol means: "ATTENTION! BECOME ALERT! YOUR SAFETY IS INVOLVED!" The Symbol and Signal Word are intended to warn the owner/operator of impending hazards and the degree of possible injury faced when operating this equipment.

Practice all usual and customary safe working precautions and above all--remember safety is up to YOU. Only YOU can prevent serious injury or death from unsafe practices.



Indicates an imminently hazardous situation that, if not avoided, WILL result in DEATH OR VERY SERIOUS INJURY.



Indicates an imminently hazardous situation that, if not avoided, COULD result in DEATH OR SERIOUS INJURY.



Indicates an imminently hazardous situation that, if not avoided, MAY result in MINOR INJURY.



Identifies special instructions or procedures that, if not strictly observed, could result in damage to, or destruction of the machine, attachments or the environment.

**NOTE:** *Identifies points of particular interest for more efficient and convenient operation or repair.* (SG-1)

READ, UNDERSTAND, and FOLLOW the following Safety Messages. Serious injury or death may occur unless care is taken to follow the warnings and instructions stated in the Safety Messages. Always use good common sense to avoid hazards. (SG-2)



Si no lee ingles, pida ayuda a alguien que si lo lea para que le traduzca las medidas de seguridad. (SG-3)

¡ LEA EL INSTRUCTIVO!





# SAFETY

## **⚠ DANGER**

Never operate the Tractor or Implement until you have read and completely understand this Manual, the Tractor Operator's Manual, and each of the Safety Messages found in the Manual or on the Tractor and Implement. Learn how to stop the tractor engine suddenly in an emergency. Never allow inexperienced or untrained personnel to operate the Tractor and Implement without supervision. Make sure the operator has fully read and understood the manuals prior to operation.

(SG-4)

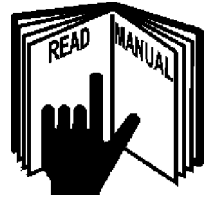

## **⚠ WARNING**

Make certain that the "Slow Moving Vehicle" (SMV) sign is installed in such a way as to be clearly visible and legible. When transporting the Equipment use the Tractor flashing warning lights and follow all local traffic regulations. (SG-6)

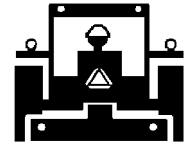

## **⚠ WARNING**

Always maintain the safety signs in good readable condition. If the safety signs are missing, damaged, or unreadable, obtain and install replacement safety signs immediately. (SG-5)

## **⚠ WARNING**

Operate this Equipment only with a Tractor equipped with an approved roll-over-protective system (ROPS). Always wear seat belts. Serious injury or even death could result from falling off the tractor--particularly during a turnover when the operator could be pinned under the ROPS. (SG-7)



## **⚠ WARNING**

Do not modify or alter this Implement. Do not permit anyone to modify or alter this Implement, any of its components or any Implement function. (SG-8)

## **⚠ DANGER**

BEFORE leaving the tractor seat, always engage the brake and/or set the tractor transmission in parking gear, disengage the PTO, stop the engine, remove the key, and wait for all moving parts to stop. Place the tractor shift lever into a low range or parking gear to prevent the tractor from rolling. Never dismount a Tractor that is moving or while the engine is running. Operate the Tractor controls from the tractor seat only. (SG-9)

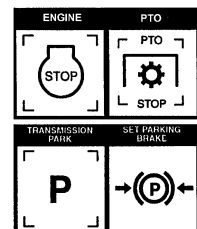

## **⚠ DANGER**

Never allow children or other persons to ride on the Tractor or Implement. Falling off can result in serious injury or death. (SG-10)



SAFETY

# SAFETY

**⚠ DANGER**

Never allow children to operate, ride on, or come close to the Tractor or Implement. Usually, 16-17 year-old children who are mature and responsible can operate the implement with adult supervision, if they have read and understand the Operator's Manuals, been trained in proper operation of the tractor and Implement, and are physically large enough to reach and operate the controls easily. (SG-11)



**⚠ WARNING**

Do not mount the Tractor while the tractor is moving. Mount the Tractor only when the Tractor and all moving parts are completely stopped. (SG-12)



**⚠ DANGER**

Start tractor only when properly seated in the Tractor seat. Starting a tractor in gear can result in injury or death. Read the Tractor operators manual for proper starting instructions. (SG-13)



**⚠ DANGER**

Never work under the Implement, the framework, or any lifted component unless the Implement is securely supported or blocked up to prevent sudden or inadvertent falling which could cause serious injury or even death. (SG-14)



**⚠ WARNING**

The operator and all support personnel should wear hard hats, safety shoes, safety glasses, and proper hearing protection at all times for protection from injury including injury from items that may be thrown by the equipment. (SG-16)

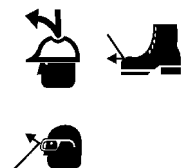

**⚠ CAUTION**

PROLONGED EXPOSURE TO LOUD NOISE MAY CAUSE PERMANENT HEARING LOSS! Tractors with or without an Implement attached can often be noisy enough to cause permanent hearing loss. We recommend that you always wear hearing protection if the noise in the Operator's position exceeds 80db. Noise over 85db over an extended period of time will cause severe hearing loss. Noise over 90db adjacent to the Operator over an extended period of time will cause permanent or total hearing loss. **NOTE:** *Hearing loss from loud noise [from tractors, chain saws, radios, and other such sources close to the ear] is cumulative over a lifetime without hope of natural recovery.* (SG-17)



# SAFETY

## **WARNING**

Periodically inspect all moving parts for wear and replace when necessary with authorized service parts. Look for loose fasteners, worn or broken parts, and leaky or loose fittings. Make sure all pins have cotter pins and washers. Serious injury may occur from not maintaining this machine in good working order. (SG-21)

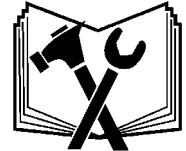
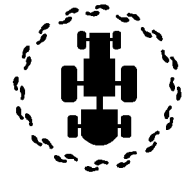

## **WARNING**

Never attempt to lubricate, adjust, or remove material from the Implement while it is in motion or while tractor engine is running. (SG-20)

## **WARNING**

Transport only at speeds where you can maintain control of the equipment. Serious accidents and injuries can result from operating this equipment at high speeds. Understand the Tractor and Implement and how it handles before transporting on streets and highways. Make sure the Tractor steering and brakes are in good condition and operate properly.



Before transporting the Tractor and Implement, determine the proper transport speeds for you and the equipment. Make sure you abide by the following rules:

Test the tractor at a slow speed and increase the speed slowly. Apply the Brakes smoothly to determine the stopping characteristics of the Tractor and Implement. As you increase the speed of the Tractor the stopping distance increases. Determine the maximum transport speed not to exceed 20 mph (30 kph) for transporting this equipment.

Test the equipment at a slow speed in turns. Increase the speed through the turn only after you determine that the equipment can be operated at a higher speed. Use extreme care and reduce your speed when turning sharply to prevent the tractor and implement from turning over. Determine the maximum turning speed for you and this equipment before operating on roads or uneven ground.

Only transport the Tractor and Implement at the speeds which allow you to properly control the equipment.

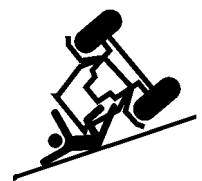

Be aware of the operating conditions. Do not operate the Tractor with weak or faulty brakes or worn tires. When operating down a hill or on wet or rain slick roads, the braking distance increases: use extreme care and reduce your speed. When operating in traffic always use the Tractor's flashing warning lights and reduce your speed. Be aware of traffic around you and watch out for the other guy. (SG-19)

SAFETY

# SAFETY



Always read carefully and comply fully with the manufacturer's instructions when handling oil, solvents, cleansers, and any other chemical agent. (SG-22)



Never run the Tractor engine in a closed building or without adequate ventilation. The exhaust fumes can be hazardous to your health. (SG-23)



KEEP AWAY FROM ROTATING ELEMENTS to prevent entanglement and possible serious injury or death. (SG-24)



Never allow children to play on or around Tractor or Implement. Children can slip or fall off the Equipment and be injured or killed. Children can cause the Implement to shift or fall crushing themselves or others. (SG-25)



Do not exceed the rated PTO speed for the Implement. Excessive PTO speeds can cause Implement driveline or blade failures resulting in serious injury or death. (SG-26)



NEVER use drugs or alcohol immediately before or while operating the Tractor and Implement. Drugs and alcohol will affect an operator's alertness and coordination and therefore affect the operator's ability to operate the equipment safely. Before operating the Tractor or Implement, an operator on prescription or over-the-counter medication must consult a medical professional regarding any side effects of the medication that would hinder their ability to operate the Equipment safely. NEVER knowingly allow anyone to operate this equipment when their alertness or coordination is impaired. Serious injury or death to the operator or others could result if the operator is under the influence of drugs or alcohol. (SG-27)



Mow only in conditions where you have clear visibility in daylight or with adequate artificial lighting. Never mow in darkness or foggy conditions where you cannot clearly see at least 100 yards(90 m) in front and to the sides of the tractor and mower. Make sure that you can clearly see and identify passersby, steep slopes, ditches, drop-offs, overhead obstructions, power lines, debris and foreign objects. If you are unable to clearly see these type of items discontinue mowing. (SGM-1)

# SAFETY



There are obvious and hidden potential hazards in the operation of this Mower. REMEMBER! This machine is often operated in heavy brush and in heavy weeds. The Blades of this Mower can throw objects if shields are not properly installed and maintained. Serious injury or even death may occur unless care is taken to insure the safety of the operator, bystanders, or passersby in the area. Do not operate this machine with anyone in the immediate area. Stop mowing if anyone is within 100 yards of mower. (SGM-2)



All Safety Shields, Guards and Safety devices including (but not limited to) - the Deflectors, Chain Guards, Steel Guards, Gearbox Shields, PTO integral shields, and Retractable Door Shields should be used and maintained in good working condition. All safety devices should be inspected carefully at least daily for missing or broken components. Missing, broken, or worn items must be replaced at once to reduce the possibility of injury or death from thrown objects, entanglement, or blade contact. (SGM-3)

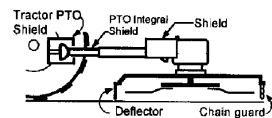

The rotating parts of this machine have been designed and tested for rugged use. However, the blades could fail upon impact with heavy, solid objects such as metal guard rails and concrete structures. Such impact could cause the broken objects to be thrown outward at very high velocities. To reduce the possibility of property damage, serious injury, or even death, never allow the cutting blades to contact such obstacles. (SGM-4)



Extreme care should be taken when operating near loose objects such as gravel, rocks, wire, and other debris. Inspect the area before mowing. Foreign objects should be removed from the site to prevent machine damage and/or bodily injury or even death. Any objects that cannot be removed must be clearly marked and carefully avoided by the operator. Stop mowing immediately if blades strike a foreign object. Repair all damage and make certain rotor or blade carrier is balanced before resuming mowing. (SGM-5)



Many varied objects, such as wire, cable, rope, or chains, can become entangled in the operating parts of the mower head. These items could then swing outside the housing at greater velocities than the blades. Such a situation is extremely hazardous and could result in serious injury or even death. Inspect the cutting area for such objects before mowing. Remove any like object from the site. Never allow the cutting blades to contact such items. (SGM-6)



Mow at the speed that you can safely operate and control the tractor and mower. The correct mowing speed depends on terrain condition and grass type, density, and height of cut. Normal ground speed range is from 2 to 5 mph(3-8 kph). Use slow mowing speeds when operating on or near steep slopes, ditches, drop-offs, overhead obstructions, power lines, or when debris and foreign objects are to be avoided. (SGM-7)

# SAFETY

**WARNING**

Avoid mowing in reverse direction when possible. Check to make sure there are no persons behind the mower and use extreme care when mowing in reverse. Mow only at a slow ground speed where you can safely operate and control the tractor and mower. Never mow an area that you have not inspected and removed debris or foreign material.

(SGM-8)

**WARNING**

Do not put hands or feet under mower decks. Blade Contact can result in serious injury or even death. Stay away until all motion has stopped and the decks are securely blocked up. (SGM-9)

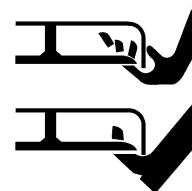

**ANGER**

Replace bent or broken blades with new blades. NEVER ATTEMPT TO STRAIGHTEN, WELD, OR WELD HARDFACING ON BLADES SINCE THIS WILL LIKELY CRACK OR OTHERWISE DAMAGE THE BLADE WITH SUBSEQUENT FAILURE AND POSSIBLE SERIOUS INJURY FROM THROWN BLADES. (SGM-10)

**WARNING**

Do not let the Blades turn when the Mower Deck is raised for any reason, including clearance or for turning. Raising the Mower deck exposes the Cutting Blades which creates a potentially serious hazard and could cause serious injury or even death from objects thrown from the Blades. (SRM-7)



**WARNING**

Never leave the Tractor and Implement unattended while the Implement is in the lifted position. Accidental operation of lifting lever or a hydraulic failure may cause sudden drop of unit with injury or death by crushing. To properly park the implement when disconnecting it from the tractor, lower the stand and put the retaining pin securely in place, or put a secure support under the A-Frame. Lower the implement carefully to the ground. Do not put hands or feet under lifted components. (S3PT-1)

# SAFETY



Rotary Mowers are capable under adverse conditions of throwing objects for great distances (300 feet or more) and causing serious injury or death. Follow safety messages carefully.



## STOP MOWING IF PASSERSBY ARE WITHIN 100 YARDS UNLESS:

- Front and Rear Deflectors, Chain Guards, or Bands are installed and in good, workable condition;
- Mower sections or Wings are running close to and parallel to the ground without exposed Blades;
- Passersby are outside the existing thrown-object zone;
- All areas have been thoroughly inspected and all foreign material such as rocks, cans, glass, and general debris has been removed.

**NOTE:** *Where there are grass and weeds high enough to hide debris that could be struck by the blades, the area should be: inspected and large debris removed, mowed at an intermediate height, inspected, closely with any remaining debris being removed, and mowed again at desired final height. (This will also reduce power required to mow, reduce wear and tear on the Mower drivetrain, spread cut material better, reduce streaking, and make the final cut more uniform).* (SRM-1)



Be particularly careful when transporting the Implement with the Tractor. Turn curves or go up hills only at a low speed and using a gradual steering angle. Rear mounted implements move the center of gravity to the rear and remove weight from the front wheels. Make certain, by adding front ballast, that at least 20% of the tractor's weight is on the front wheels to prevent rearing up, loss of steering control or Tractor tip-over. Slow down on rough or uneven surfaces to prevent loss of steering control which could result in property damage or possible injury. Do not transport unless 3-Point lift lever is fully raised and in the latched transport position. Dropping implement in transport can cause serious damage to the tractor and/or Implement and possibly cause the operator or others to be injured or killed. (S3PT-2)



There are obvious and hidden potential hazards in the operation of this Implement as in all power-driven or pulled equipment. **REMEMBER!** This machine is often operated in rough terrain conditions that include tall grass, weeds, gullies, holes, slopes, hidden obstructions and the like. Serious injury or even death may occur unless care is taken to assure the safety of the operator and bystanders in the area. Do not operate this machine with anyone in the immediate area. (S3PT-7)



Make sure the PTO shield, integral driveline shields, and input shields are installed when using PTO-driven equipment. Always replace any shield if it is damaged or missing. (S3PT-8)



# SAFETY

**WARNING**

Relieve hydraulic pressure prior to doing any maintenance or repair work on the Implement. Place the Implement on the ground or securely blocked up, disengage the PTO, and turn off the tractor engine. Push and pull the Remote Cylinder lever in and out several times prior to starting any maintenance or repair work. (S3PT-9)



**WARNING**

The rotating parts of this machine continue to rotate even after the PTO has been turned off. The operator should remain in his seat for 60 seconds after the brake has been set, the PTO disengaged, the tractor turned off, and all evidence of rotation has ceased. (S3PT-10)

**“Wait a minute...Save a life!”**

**DANGER**

Always disconnect the main PTO Driveline from the Tractor before performing service on the Implement. Never work on the Implement with the tractor PTO driveline connected and running. Rotating Parts, Blades or Drivelines could turn without warning and cause immediate entanglement, injury or death. (S3PT-11)

**WARNING**

Only transport the Implement behind a properly sized and equipped Tractor which exceeds the weight of the Implement by at least 20%. DO NOT transport the Implement behind a truck or other type of vehicle. Never transport the Implement and another Implement connected in tandem. Never transport the Implement at speeds over 20 MPH. (STI-6)



**WARNING**

Follow these guidelines to reduce the risk of equipment and grass fires while operating, servicing, and repairing the Mower and Tractor:



- Equip the Tractor with a fire extinguisher in an accesible location.
- Do Not operate the Mower on a Tractor with an underframe exhaust.
- Do Not smoke or have an open flame near the Mower and Tractor.
- Do Not drive into burning debris or freshly burnt areas.
- Ensure slip clutches are properly adjusted to prevent excessive slippage and plate heating.
- Never allow clippings or debris to collect near drivelines, slip clutches, and gearboxes. Periodically shut down the Tractor and Mower and clean clippings and collected debris from the mower deck. (SGM-12)

**WARNING**

Do not mow with two machines in the same area except with Cab tractors with the windows closed. (SGM-11)



# SAFETY



Replace bent or broken blades with new blades. NEVER ATTEMPT TO STRAIGHTEN, WELD, OR WELD HARDFACING ON BLADES SINCE THIS WILL LIKELY CRACK OR OTHERWISE DAMAGE THE BLADE WITH SUBSEQUENT FAILURE AND POSSIBLE SERIOUS INJURY FROM THROWN BLADES. (SGM-10)

## PARTS INFORMATION

Rhino mowers use balanced and matched system components for blade carriers, blades, cuttershafts, knives, knife hangers, rollers, drivetrain components, and bearings. These parts are made and tested to Rhino specifications. Non-genuine "will fit" parts do not consistently meet these specifications. The use of "will fit" parts may reduce mower performance, void warranties, and present a safety hazard. Use genuine Rhino mower parts for economy and safety. (SPRM-1)

## SEE YOUR RHINO DEALER

In addition to the design and configuration of this Implement, including Safety Signs and Safety Equipment, hazard control and accident prevention are dependent upon the awareness, concern, prudence, and proper training of personnel involved in the operation, transport, maintenance, and storage of the machine. Refer also to Safety Messages and operation instruction in each of the appropriate sections of the Tractor and Equipment Manuals. Pay close attention to the Safety Signs affixed to the Tractor and Equipment. (SG-18)

SAFETY

# SAFETY

## Decal Location

NOTE: Rhino supplies safety decals on this product to promote safe operation. Damage to the decals may occur while in shipping, use, or reconditioning. Rhino cares about the safety of its customers, operators, and bystanders, and will replace the safety decals on this product in the field, free of charge (Some shipping and handling charges may apply). Contact your Rhino dealer to order replacement decals

## Pull-Type Unit

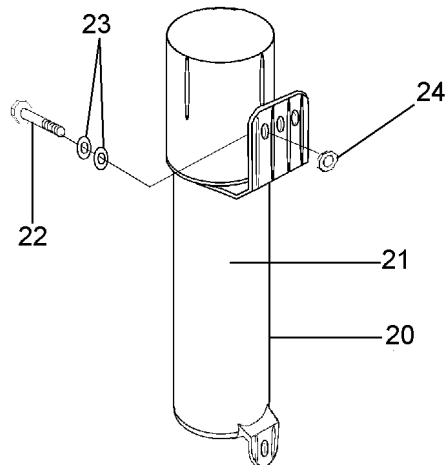
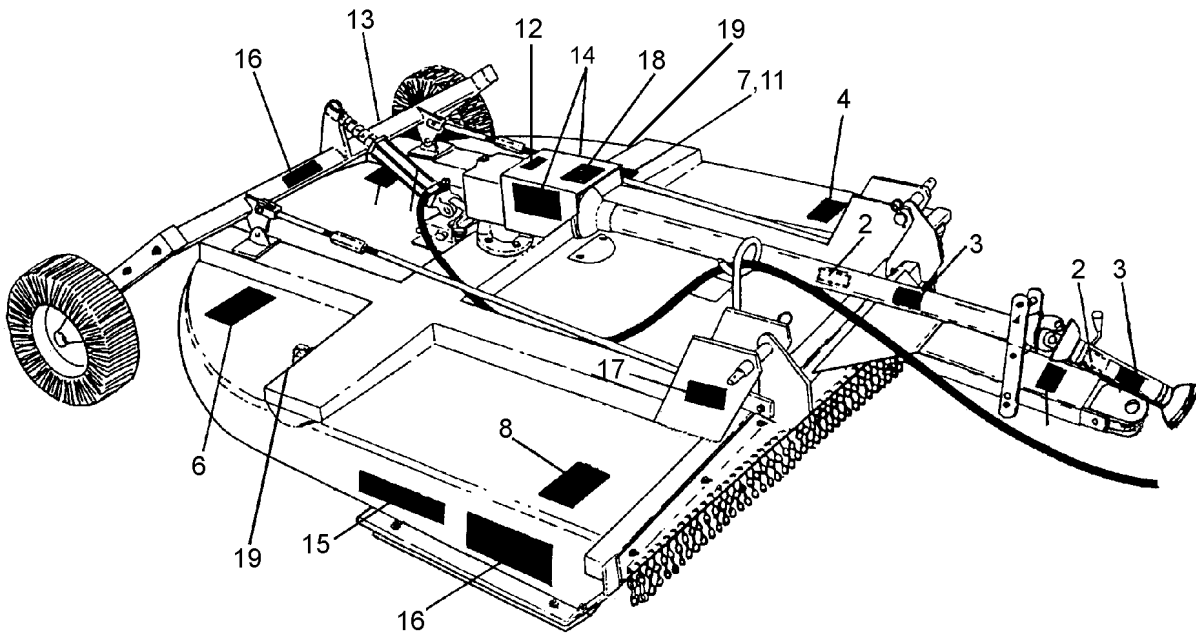

DL-0003\_A

SAFETY

# SAFETY

**SAFETY**

| ITEM | PART NO.  | QTY   | TYPE      | DESCRIPTION                        |
|------|-----------|-------|-----------|------------------------------------|
| 1.   | 00749117  | 1     | DANGER    | Multi-Hazard                       |
| 2.   | 00756004  | 1     | DANGER    | D/L Shield Missing -Do Not Operate |
| 3.   | 00756005  | 1     | DANGER    | Rotating Driveline                 |
| 4.   | 00756007  | 1     | WARNING   | Use/Repair Shields & Guards        |
| 5.   | 00756059  | 0 (1) | WARNING   | Leak Detection                     |
| 6.   | 00756485  | 1     | DANGER    | Blades/Thrown Objects              |
| 7.   | 00756494  | 1     | DANGER    | Driveline Hazards                  |
| 8.   | 00760657  | 1     | CAUTION   | Genuine Parts, Rotary              |
| 9.   | 03200347  | *     | REFLECT   | SMV                                |
| 10.  | 00764848  | 0 (1) | INSTRUCT  | Drawbar-to-PTO adj.                |
| 11.  | D114**    | 1     | INSTRUCT  | 1000 RPM PTO                       |
|      | D103**    | 1     | INSTRUCT  | 540 RPM PTO                        |
| 12.  | 00763977  | 1     | INSTRUCT  | Notice to Owner                    |
| 13.  | 99101     | 0 (1) | NAME      | Rhino (2 x 7 -3/8)                 |
| 14.  | D302      | 2     | LOGO      | Rhino (4-7/8 x 16-3/4)             |
| 15.  | D303      | 2     | NAME      | Rhino (4-3/8 x 16-3/4)             |
| 16.  | 00771526  | 2 (3) | NAME      | CY84                               |
| 17.  | nfs       | 1     | SER PLATE | CY84 Serial Plate                  |
| 18.  | 00771283  | 1     |           | 5 Year Gearbox Warranty            |
| 19.  | 1458393   | 2     | REFLECT   | Red Reflectors                     |
| 20.  | 00776031  | 1     |           | Canister, Operator's Manual        |
| 21.  | 00771528C | 1     |           | Operator's Manual                  |
| 22.  | 10058000  | 3     |           | Bolt                               |
| 23.  | 00024100  | 6     |           | Flatwasher                         |
| 24.  | 02959924  | 3     |           | Locknut                            |

( ) Quantities for Pull-Type Only

\*\* 540 or 1000 RPM units only. Select correct one.

\* Furnished by the tractor manufacturer.

**Complete Decal Sheet**

**00773316**

# SAFETY

## Lift-Type Unit

SAFETY

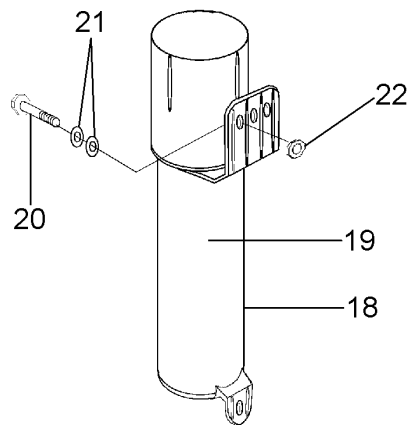
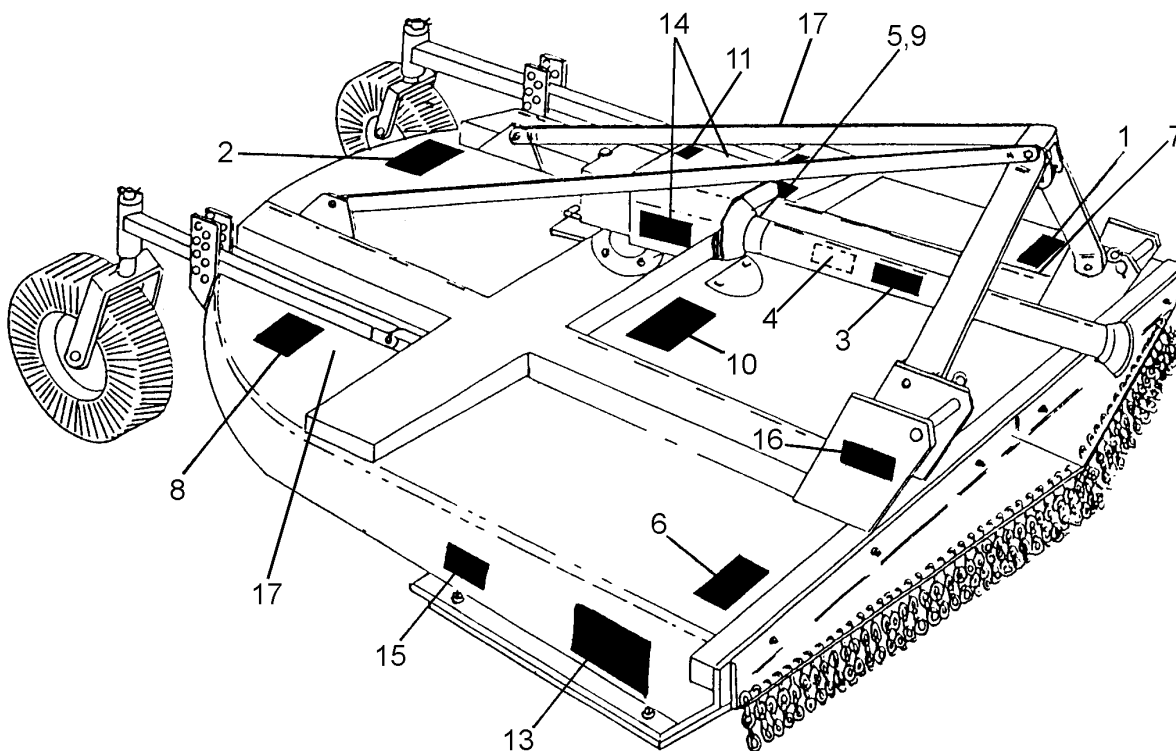

DL-0004\_A

# SAFETY

**SAFETY**

| ITEM | PART NO.  | QTY | TYPE     | DESCRIPTION                        |
|------|-----------|-----|----------|------------------------------------|
| 1.   | 00725746  | 1   | PELIGRO  | Get Manual Translated              |
| 2.   | 00749117  | 1   | DANGER   | Multi-Hazard                       |
| 3.   | 00756005  | 1   | DANGER   | Rotating Driveline                 |
| 4.   | 00756004  | 1   | DANGER   | D/L Shield Missing -Do Not Operate |
| 5.   | 00756494  | 1   | DANGER   | Driveline Hazards                  |
| 6.   | 00760657  | 1   | CAUTION  | Genuine Parts, Rotary              |
| 6a.  | 00773723  | 1   | PELIGRO  | Rotating Driveline Translation     |
| 7.   | 00769736  | 1   | WARNING  | Use Repair Shields and Guards      |
| 8.   | 00769737  | 1   | DANGER   | Blades/Thrown Objects              |
| 9.   | D103      | 1   | INSTRUCT | 540 RPM PTO                        |
| 10.  | 00763613  | 1   | INSTRUCT | Slip Clutch                        |
| 11.  | 00763977  | 1   | INSTRUCT | Notice to Owner                    |
| 12.  | 03200347  | *   | REFLECT  | SMV Emblem                         |
| 13.  | D303      | 2   | L.NAME   | Rhino (4-3/8 x 16-3/4)             |
| 14.  | D302      | 2   | LOGO     | Rhino (4-7/8 x 6-1/2)              |
| 15.  | 00771526  | 2   | NAME     | CY84                               |
| 16.  | nfs       | 1   | PLATE    | CY84 Serial Plate                  |
| 17.  | 1458393   | 2   | REFLECT  | Red Reflector                      |
| 18.  | 00776031  | 1   |          | Canister, Operator's Manual        |
| 19.  | 00771528C | 1   |          | Operator's Manual                  |
| 20.  | 10058000  | 3   |          | Bolt                               |
| 21.  | 00024100  | 6   |          | Flatwasher                         |
| 22.  | 02959924  | 3   |          | Locknut                            |

\* Furnished by the tractor manufacturer.

# SAFETY

SAFETY

## Decal Description

DANGER! Multi-Hazard Decal  
(Refer To Front Cover)



P/N 00749117

DANGER! Guard Missing, Do Not Operate. If you see this decal, Do Not Operate the mower until the shield has been replaced.



P/N 00756004

DANGER! Rotating Driveline Keep Away, Contact can cause death.



P/N 00756005

WARNING! Keep all safety shielding installed, repaired and replaced when damaged so that machine stays in safe condition.

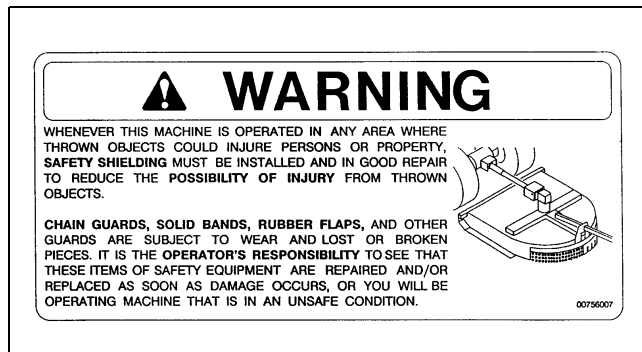

P/N 00756007

# SAFETY

WARNING! Never use your hand to check for oil leaks. Always use paper or cardboard.

P/N 00756059

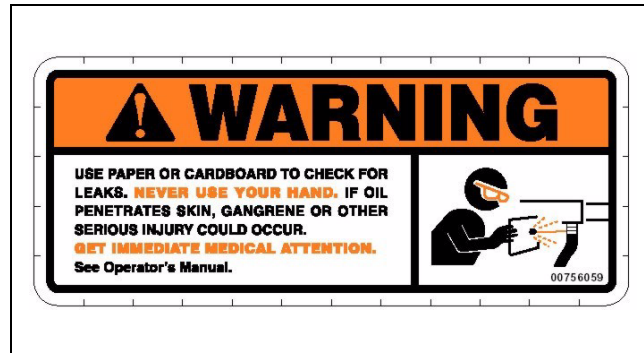

DANGER! Keep Away - Rotating Blades

P/N 00756485

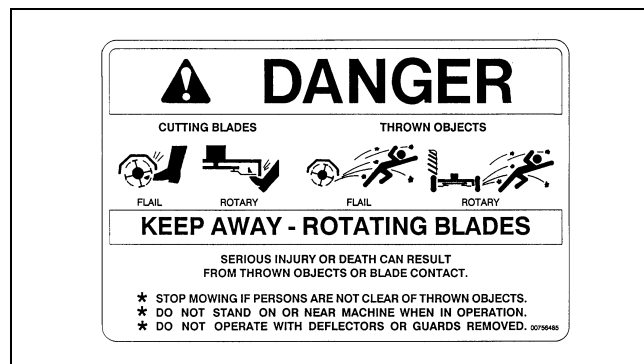

DANGER! Make certain that drivelines are correct length and are securely attached.

P/N 00756494

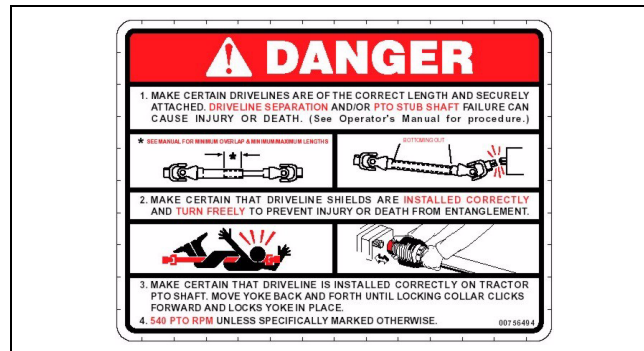

For safety and to guarantee optimum product reliability always use genuine RHINO replacement parts.

P/N 00760657

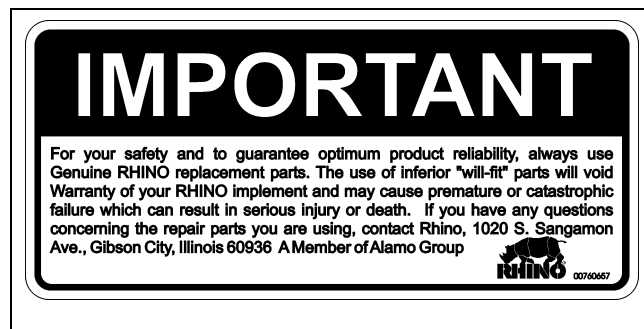

SAFETY

# SAFETY

Slow Moving Vehicle Decal. Keep SMV reflector clean and visible. DO NOT transport or operate without the SMV.

Provided by Tractor Manufacturer. Replace if missing on tractor.

P/N 03200347

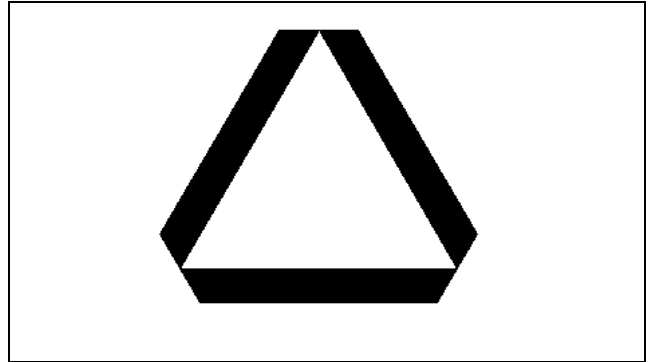

IMPORTANT! - Required for Equal-Angle Driveline Unit.

P/N 00764848

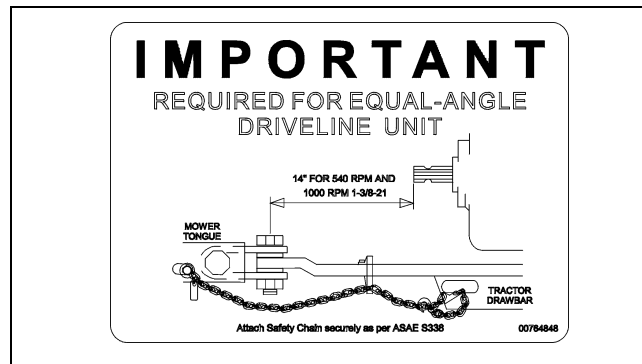

WARNING! Avoid Bodily Injury, Use 1000 RPM PTO Speed Only.

P/N D114



WARNING! Avoid Bodily Injury, Use 540RPM PTO Speed Only.

P/N D103





# SAFETY

Operator's Manual (with repair parts) and warranty was attached to this implement during final inspection.

P/N 00763977

LOGO NAME

P/N 99101

Logo Product Name: Rhino

P/N D302

Logo Product Name: Rhino

P/N D303

CY84 03/08

Safety Section 1-19

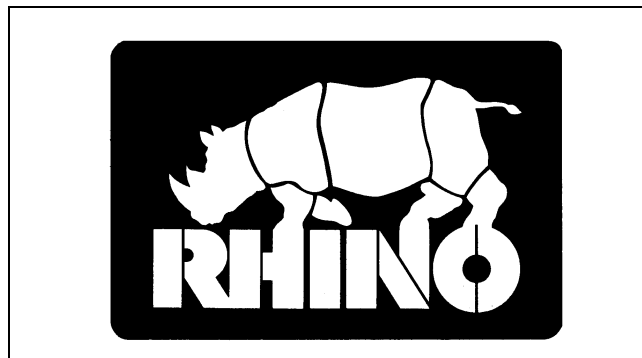
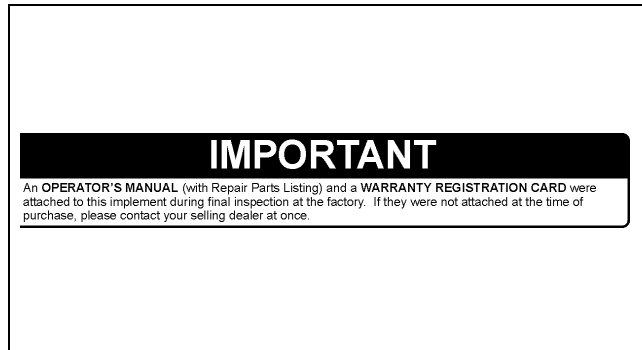

**SAFETY**

# SAFETY

SAFETY

CY84 Logo



P/N 00771526

INFORMATION - 5 Year Gearbox Warranty



P/N 00771283

Amber Reflector. Keep reflectors clean and visible.

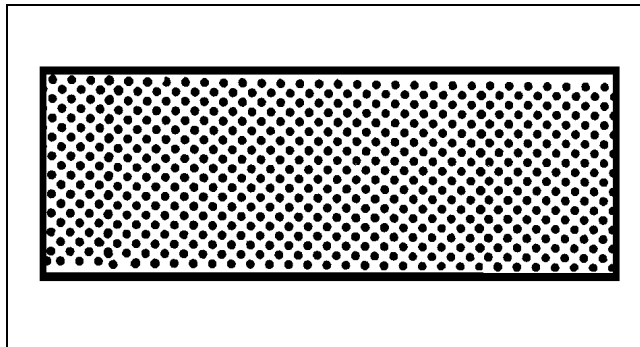

P/N 1458393

Peligro Translation, If you do not know how to read English, please find someone who knows how to read English.



P/N 00725746

# SAFETY

PELIGRO! Spanish Translation for Driveline Safety



P/N 00773723

WARNING! Maintain shields and deflectors in good condition. Failure to do so may lead to injury or even death.



P/N 00769736

DANGER! Keep Away Thrown Objects. Inspect the area before mowing and remove foreign material that could become mower thrown objects.

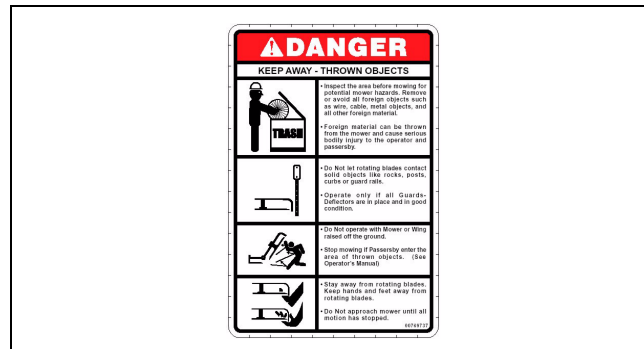

P/N 00769737

Attention! Do not operate until all slip clutches are properly adjust and are not frozen.

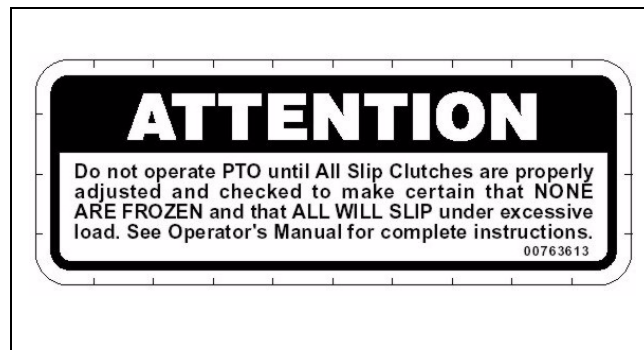

P/N 00763613

SAFETY

# SAFETY

Read Operator's Manual! The operator's manual is located inside this canister. If the manual is missing order one from your dealer.

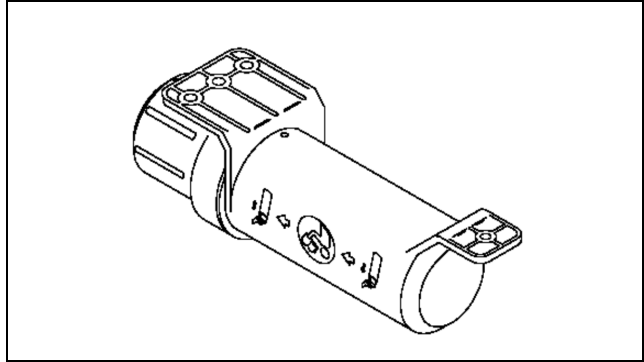

P/N 00776031

SAFETY

# SAFETY

## **Federal Laws and Regulations**

This section is intended to explain in broad terms the concept and effect of federal laws and regulations concerning employer and employee equipment operators. This section is not intended as a legal interpretation of the law and should not be considered as such.

### **Employer-Employee Operator Regulations**

U.S. Public Law 91-596 (The Williams-Steiger Occupational and Health Act of 1970) OSHA

#### **This Act Seeks:**

“...to assure so far as possible every working man and woman in the nation safe and healthful working conditions and to preserve our human resources...”

#### **DUTIES**

Sec. 5 (a) Each employer-

(1) shall furnish to each of his employees employment and a place of employment which are free from recognized hazards that are causing or are likely to cause death or serious physical harm to his employees;

(2) shall comply with occupational safety and health standards promulgated under this Act.

(b) Each employee shall comply with occupational safety and health standards and all rules, regulations and orders issued pursuant to this Act which are applicable to his own actions and conduct.

#### **OSHA Regulations**

OSHA regulations state in part: “At the time of initial assignment and at least annually thereafter, the employer shall instruct every employee in the safe operation and servicing of all equipment with which the employee is, or will be involved.”

### **Employer Responsibilities:**

To ensure employee safety during Tractor and Implement operation, it is the employer’s responsibility to:

1. Train the employee in the proper and safe operation of the Tractor and Implement.
2. Require that the employee read and fully understand the Tractor and Implement Operator’s manual.
3. Permit only qualified and properly trained employees to operate the Tractor and Implement.
4. Maintain the Tractor and Implement in a safe operational condition and maintain all shields and guards on the equipment.
5. Ensure the Tractor is equipped with a functional ROPS and seat belt and require that the employee operator securely fasten the safety belt and operate with the ROPS in the raised position at all times.
6. Forbid the employee operator to carry additional riders on the Tractor or Implement.
7. Provide the required tools to maintain the Tractor and Implement in a good safe working condition and provide the necessary support devices to secure the equipment safely while performing repairs and service.
8. Require that the employee operator stop operation if bystanders or passerbys come within 25 feet.

### **Child Labor Under 16 Years of Age**

Some regulations specify that no one under the age of 16 may operate power machinery. It is your responsibility to know what these regulations are in your own area or situation. (Refer to U.S. Dept. of Labor, Employment Standard Administration, Wage & Home Division, Child Labor Bulletin #102.)





# Safety Manual

*For Operators  
and Mechanics*

# Industrial/ Agricultural Mower

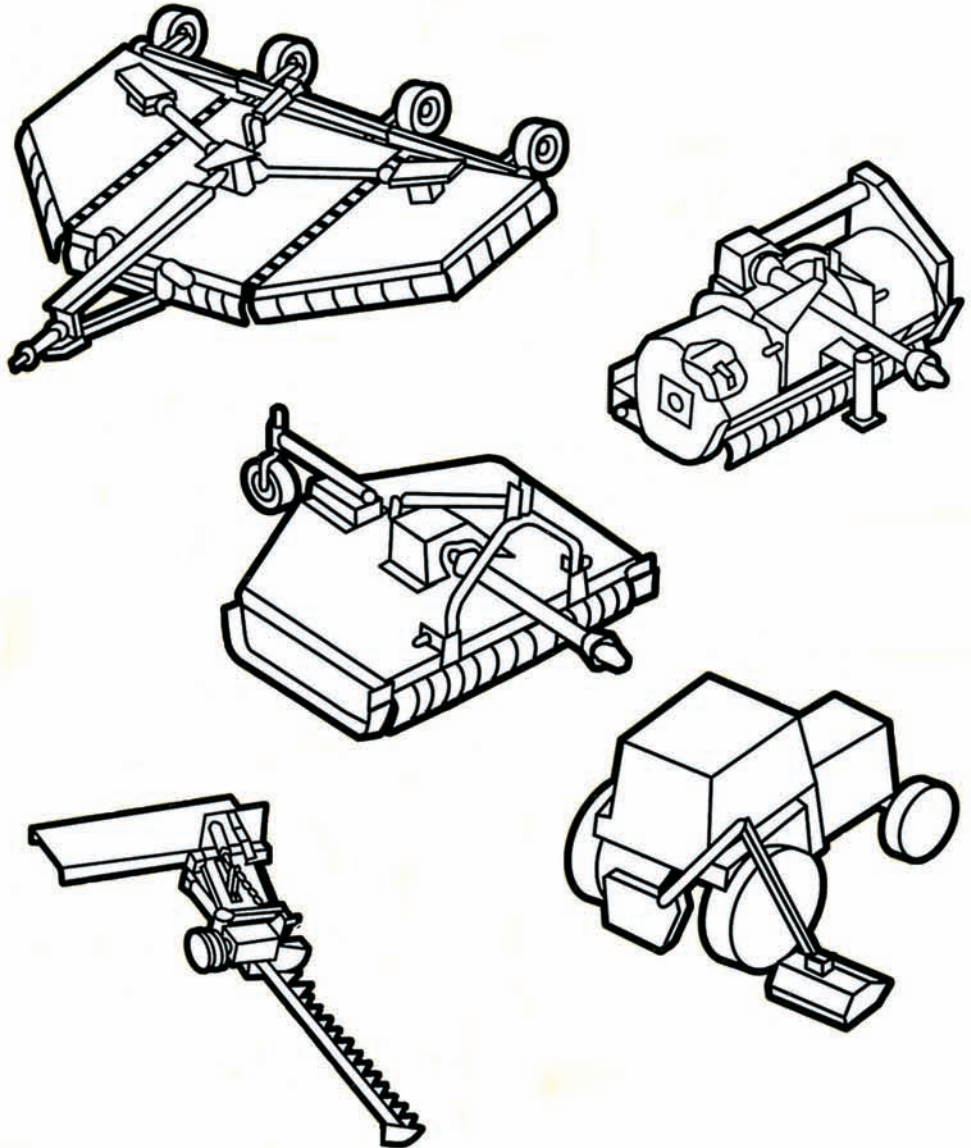

111 E. Wisconsin Avenue • Milwaukee, Wisconsin 53202 U.S.A.  
[www.aem.org](http://www.aem.org)

# **Contents**

---

|   |    |
|---|----|
| <b>Acknowledgement</b> .....                        | 2  |
| <b>Forward</b> .....                                | 3  |
| <b>A Word to the User</b> .....                     | 3  |
| <b>Safety Alert Symbol</b> .....                    | 4  |
| <b>Industrial/Agricultural Mower Types</b> .....    | 4  |
| <b>Be a Responsible Operator</b> .....              | 5  |
| <b>Safety Management of Hazards and Risks</b> ..... | 6  |
| <b>Follow a Safety Program</b> .....                | 11 |
| <b>Safety-Before Operation</b> .....                | 11 |
| <b>Safety-Starting and Testing</b> .....            | 13 |
| <b>Safety-During Operation</b> .....                | 14 |
| <b>Safety-During Shutdown</b> .....                 | 18 |
| <b>Safety-During Maintenance</b> .....              | 19 |
| <b>One Final Word</b> .....                         | 21 |

# **Acknowledgement**

---

We wish to acknowledge the contributions of the members of the Association of Equipment Manufacturers to the preparation of this Safety Manual.

**Copyright**  
© 2000 AEM (formerly Equipment Manufacturers Institute). Revised 08.2003. All rights reserved.



## Forward

---

This Safety Manual is intended to point out some of the basic safety situations which may be encountered during the normal operation and maintenance of your machine and to suggest possible ways of dealing with these conditions. This manual is NOT a substitute for the manufacturer's manual(s).

Additional precautions may be necessary, or some instructions may not be applicable, depending on the equipment, attachment devices, and conditions at the worksite or in the service area. The manufacturer has no direct control over machine application, operation, inspection, lubrication, or maintenance. Therefore, it is **YOUR** responsibility to use good safety practices in these areas.

The information provided in this manual supplements the specific information about your machine that is contained in the manufacturer's manual(s). Other information which may affect the safe operation of your machine may be contained on safety signs or in insurance requirements, employer's safety and training programs, safety codes, local, state/provincial and national laws, rules and regulations.

**IMPORTANT:** *If you do not have the manufacturer's manual(s) for your particular machine, get a replacement manual from your employer, equipment dealer, or the manufacturer of your machine. Keep this safety manual and the manufacturer's manual(s) with your machine.*

## A Word to the User

---

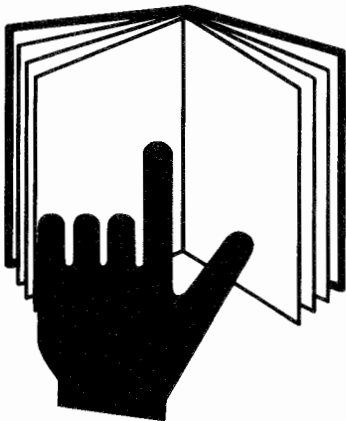

It is your responsibility to read and understand this safety manual and the manufacturer's manual(s) before operating this machine. This safety manual takes you step-by-step through your working day. The safety manual, manufacturer's manual(s), safety signs (decals) and safety precautions must be explained to those users or operators who cannot read the material.

In addition to equipment design and configuration, **HAZARD CONTROL** and **ACCIDENT PREVENTION** are dependent upon the owner's and operator's awareness, concern, prudence, and proper training in the operation, transport, maintenance and storage of equipment.

Remember that **YOU** are the key to safety. Good safety practices not only protect you but also protect the people around you. Study this manual and the manufacturer's manual(s) for your specific machine. Make them a working part of your safety program. Keep in mind that this safety manual is written only for industrial and agricultural mowers.

**Practice all usual and customary safe working precautions and above all – remember safety is up to YOU. Only YOU can prevent serious injury or death from unsafe practices.**

# Safety Alerts

## Symbol

This Safety Alert Symbol means:

**“ATTENTION! BECOME ALERT!  
YOUR SAFETY IS INVOLVED!”**

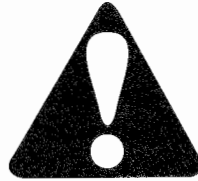

The Safety Alert Symbol identifies important safety messages on equipment, safety signs, in manuals or elsewhere. When you see this symbol, be alert to the possibility of death or personal injury. Follow the instructions in the safety message.

## Signal Words

Signal words are distinctive words that will typically be found on safety decals on this equipment or other equipment on the worksite. These words are intended to alert the viewer to the existence and relative degree of a hazard.



This signal word indicates an imminently hazardous situation which, not avoided, will result in death or serious injury.



This signal word indicates a potentially hazardous situation which, if not avoided, could result in death or serious injury.



This signal word indicates a potentially hazardous situation exists which, if not avoided, may result in minor or moderate injury.

- ACCIDENTS DISABLE AND KILL.
- ACCIDENTS COST.
- ACCIDENTS CAN BE AVOIDED.

# Industrial/Agricultural Mowers

A mower for pasture clipping, crop residue shredding, heavy brush cutting for land clearing, waterways, right-of-ways, road side or highway mowing.

## INDUSTRIAL/AGRICULTURAL MOWER TYPES:

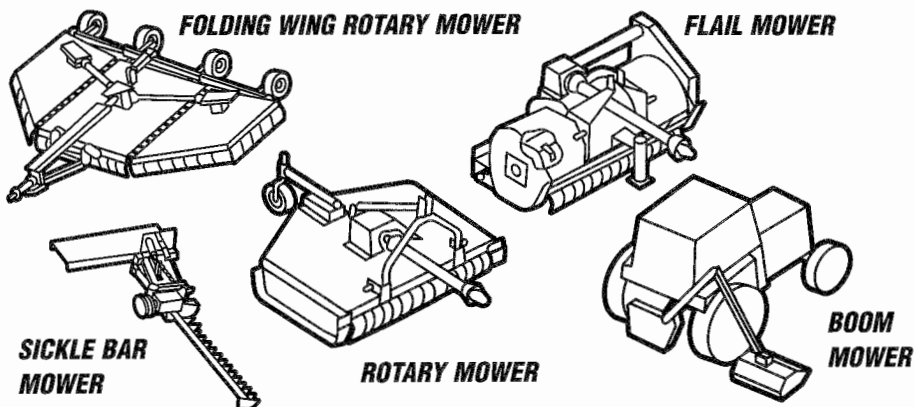

# Be a Responsible Operator



**DON'T**  
Drink & Drive



**DON'T**  
Take  
Drugs & Drive

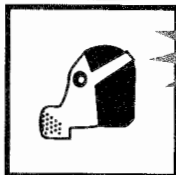
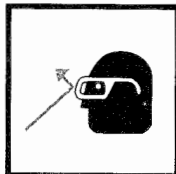
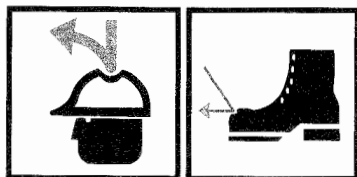

**PROTECT**  
Yourself



**CALL**  
For Assistance

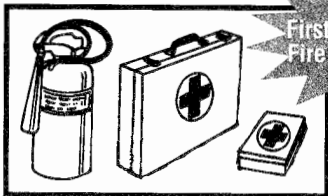

**LOCATE**  
First Aid Kits and  
Fire Extinguisher

For safe operation of your equipment, you must be a responsible operator. A responsible operator must clearly understand the written instructions supplied by the manufacturer, be trained—including actual operation of the equipment and know the safety rules and regulations for the worksite.

Drugs and alcohol will affect an operator's alertness and coordination and therefore affect the operator's ability to operate the equipment safely. An operator should **NEVER** use drugs which affect alertness, judgement and coordination or alcohol while operating motorized equipment, including tractors and mowers. An operator on prescription or over-the-counter medication must consult a medical professional regarding any side effects of the medication that would hinder his or her ability to operate this equipment safely. **NEVER** knowingly allow anyone to operate this equipment when their alertness, judgement or coordination is impaired.

## Protect Yourself

Wear all the protective clothing and personal safety devices issued to you or called for by job conditions.

### You may need:

- Hard hat
- Safety shoes
- Safety glasses with side shields, goggles or face shield
- Heavy gloves
- Hearing protection
- Reflective clothing
- Wet weather gear
- Respirator or filter mask

Wear adequate clothing for the job conditions.

Always know where to get assistance in the case of an emergency. Know where to find and how to use a first aid kit and fire extinguisher/fire suppression system.

**Stay alert. Avoid accidents.  
Don't learn safety the hard way.**

# Safety Management of Hazards and Risks

In addition to equipment design and configuration, **HAZARD CONTROL** and **ACCIDENT PREVENTION** are dependent upon the owner's and operator's awareness, concern, prudence, and proper training in the operation, transport, maintenance and storage of equipment.

**SAFETY MANAGEMENT OF HAZARDS AND RISKS IS ESSENTIAL TO RESPONSIBLE OWNERS AND OPERATORS OF TRACTORS AND MOWERS.**

**REVIEW THE FOLLOWING SAFETY MANAGEMENT OF LISTED HAZARDS AND RISKS:**

## ***Thrown Object Hazard***

**POSSIBLE THROWN OBJECT INJURY RISKS EXIST FOR MOWER OPERATORS AND BYSTANDERS DURING MOWER OPERATIONS FROM THE FOLLOWING:**

**DISCHARGED OBJECTS (ROCKS, DEBRIS, BROKEN MOWER BLADES, BLADE BOLTS, CABLES, CHAINS, WIRE, ETC....) FROM THE MOWER.**

## ***Equipment Protective Devices And Recommended Safety Practices***

The mower deck and protective devices cannot prevent all objects or debris from escaping the blade enclosure area in every mowing condition. It is possible for objects to escape and travel several hundred (300) feet.

### **RECOMMENDED SAFETY PRACTICES**

Read manufacturer's operator manual(s) for recommended operating safety practices. Explain the practices to users or operators who cannot read.

**TO HELP PREVENT SERIOUS INJURY OR DEATH FROM OBJECTS STRIKING OPERATOR OR OTHER PERSONS DO THE FOLLOWING:**

#### **BYSTANDERS SAFETY**

- Keep bystanders several hundred (300) feet from mowing area.

#### **EQUIPMENT PROTECTIVE DEVICES SAFETY**

**To contain, deflect or reduce thrown objects from blade enclosure area:**

- Keep chain, flexible or solid deflector shields in place on the front and rear of the mower deck and in good repair.
- Do not operate with damaged or missing thrown object shielding.

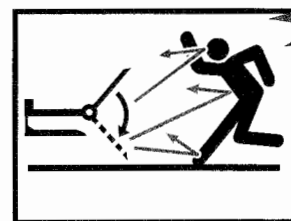
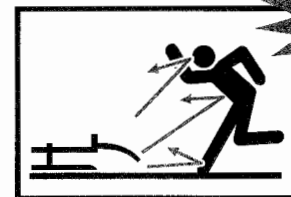
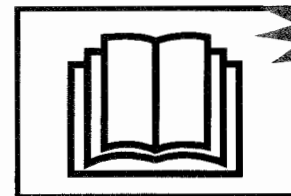
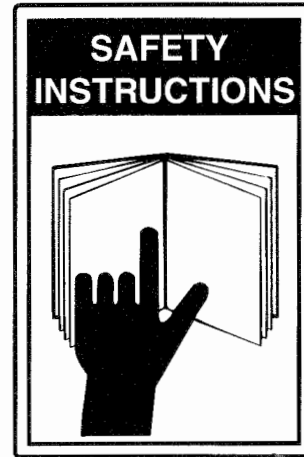

**USE ROPS  
Enclosed Cabs  
or Protective  
Enclosures**

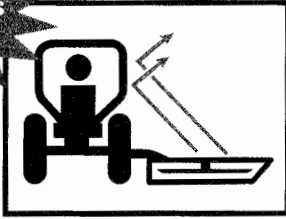

**USE Proper  
PTO Speed**

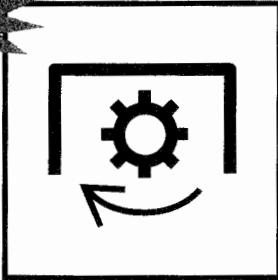

**MAINTAIN  
Equipment**



## **OPERATOR SAFETY**

Raised wings, side mount and boom type mower operations may reduce the mower's thrown object shielding effectiveness for the mower operator's protection.

**Do the following to increase operator protection from thrown objects during these mowing operations:**

- Use enclosed ROPS cabs, special protective enclosures, screens or other operator shielding devices when performing these operations.

### **EXCEEDING RECOMMENDED PTO SPEEDS**

Do not exceed manufacturer's recommended PTO speeds.

**Excessive PTO speeds may cause:**

- Blade failures
- Higher velocity objects escaping or broken blades being thrown from mower blade enclosures.
- Potential 540 rpm driveline failures operating at 750 to 1000 rpm speeds.

### **OTHER SAFETY PRACTICES:**

- Never operate mower with broken, bent, missing, or severely worn blades.
- Before mowing, remove debris and foreign objects to avoid them being picked up and thrown out by the mower.
- \* Do not operate the mower in transport or in raised wing positions.

## **RECOMMENDED MAINTENANCE PRACTICES**

Read manufacturer's operator manual(s) inspection and maintenance instructions for chain guards, flexible or solid deflector shielding:

- Replace worn or damaged guards and other shielding before mowing.
- Use only manufacturer's replacement guards and shielding. Other guarding or shielding sources may not fit or have inadequate materials to meet the strength requirements of the equipment.
- Replace worn or damaged decals and warning instructions.
- Explain the inspection and maintenance instructions to those users or operators who cannot read.

# Rotating Blades and Driveline Hazards and Risks

A POSSIBLE INJURY RISK EXISTS TO MOWER OPERATORS AND BYSTANDERS DURING MOWING OPERATIONS FROM THE FOLLOWING:

- BODY CONTACT WITH ROTATING BLADES.
- BODY ENTANGLEMENT WITH ROTATING DRIVELINES AND PARTS.

## Equipment Protective Devices and Recommended Safety Practices

### RECOMMENDED SAFETY PRACTICES

Read manufacturer's operator manual(s) for recommended operating safety practices. Explain the practices to those users or operators who cannot read. To help prevent serious injury or death from moving blade contact, driveline or parts entanglement of operators or other persons do the following:

#### BYSTANDERS SAFETY

- Do not operate near bystanders.
- Keep other persons several hundred (300) feet from the mowing area.

#### OPERATOR SAFETY PRACTICES

- Do not allow riders on tractor or mower. Securely fasten seat belt when mowing.
- Use proper equipment shutdown practice before servicing, adjusting, cleaning or unclogging the mower.
- Keep clear of rotating blades, parts, and drivelines.
- Never start tractor engine while standing beside equipment.
- Only start tractor engine while sitting in operator's seat with seat belt fastened.

#### RECOMMENDED GUARDS, DRIVELINE GUARDS AND SHIELDING SAFETY PRACTICES

- Keep guards, driveline and other shielding in place and in good repair.
- Do not operate mower with missing or damaged guards, driveline guards or other shielding.

#### RECOMMENDED MAINTENANCE PRACTICES

Read manufacturer's operator manual(s) inspection and maintenance instructions for guards, driveline guards and other shielding:

- Replace worn or damaged guards, driveline guards and other shielding before mowing.
- Use only manufacturer's replacement guards and shielding. Other guarding or shielding sources may not fit or have inadequate materials to meet the strength requirements of the equipment.
- Replace worn or damaged decals and warning instructions.
- Explain the inspection and maintenance instructions to those users or operators who cannot read.

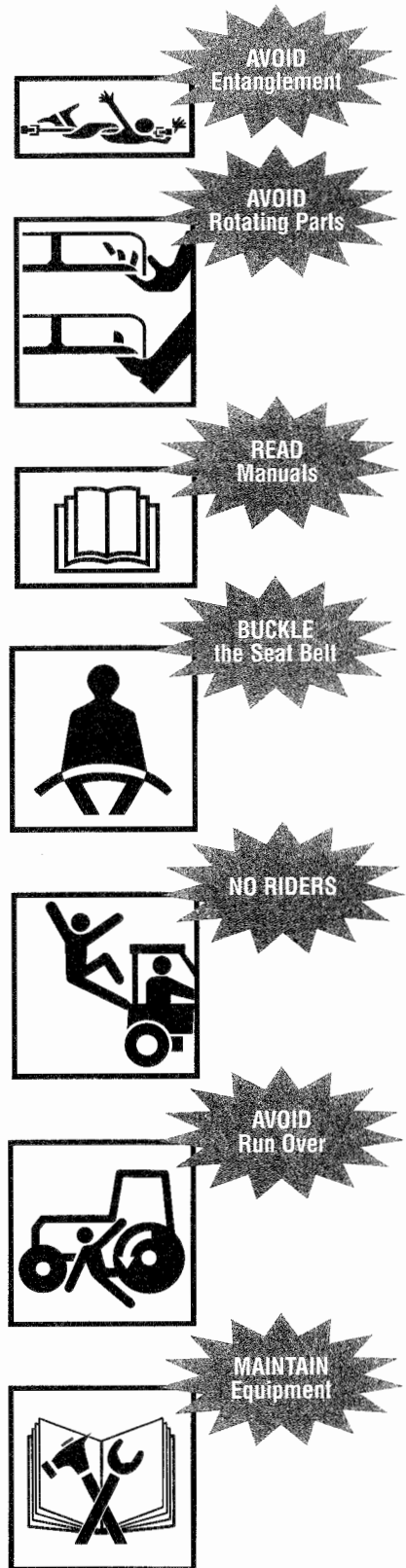

## ***Tractor and Mower Rollover or Overturn Hazards and Risks***

A POSSIBLE ROLLOVER OR OVERTURN INJURY RISK EXISTS TO MOWER OPERATORS DURING MOWING OPERATIONS FROM THE FOLLOWING:

- ROUGH TERRAIN, STEEP SLOPES, HOLES, BUMPS, RUTS, ROCKS, STUMPS OR OTHER OBSTRUCTIONS THAT COULD OVERTURN TRACTOR AND MOWER.
- EXCESSIVE GROUND SPEEDS FOR THESE TERRAIN CONDITIONS.

### ***Equipment Protective Devices and Recommended Safety Practices***

When possible remove stumps, stones, etc.. or mark them and other obstructions clearly to avoid upsets, breakdowns, and dangerous driving conditions. Use extreme care to maintain control over the equipment when operating in these terrain conditions.

#### **RECOMMENDED-TRACTOR ROPS**

A tractor equipped with ROPS or enclosed ROPS cab and seat belt for operator safety is essential for additional operator protection when operating mower in these terrain conditions.

#### **RECOMMENDED-TRACTOR STABILITY ADJUSTMENTS**

Read the tractor operator's manual for adjustments to increase tractor stability:

- Adding front and rear wheel weights or ballast.
- Adjusting wheel spacing to maximum width .
- Adding off-side counter ballast to side-mounted and boom mowers.
- Explain adjustments to those users or operators who cannot read.

### **RECOMMENDED SAFETY PRACTICES**

Read manufacturer's operator manual(s) for recommended operating safety practices. Explain the practices to those users or operators who cannot read. **To help prevent serious injury or death to the operator from tractor and mower overturns, do the following:**

- Securely fasten seat belt when mowing with ROPS equipped tractors.
- Avoid excessive ground speed for terrain conditions.
- Avoid sudden starts, stops and turns when operating up, down or across slopes.
- Avoid slippery ground conditions.
- Make wide and gradual turns.
- Plan to mow down hill on steep slopes to avoid overturning.

## ***Falling Mower or Parts Crushing Hazards and Risks***

A POSSIBLE CRUSHING INJURY RISK EXISTS FOR MOWER OPERATORS AND OTHERS DURING MOWING OPERATIONS FROM THE FOLLOWING:

- FALLING MOWER OR EQUIPMENT FROM HYDRAULIC SYSTEM FAILURE.
- FAILURE TO SECURELY SUPPORT, BLOCK-UP OR LOCK-UP LIFTED MOWER OR EQUIPMENT PARTS.

**AVOID  
Rollover**

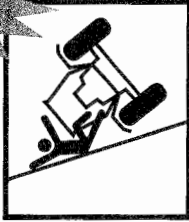

**USE  
Tractor ROPS**



**READ  
Manuals**

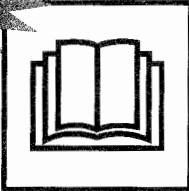

**ADD  
Ballast**



**WIDEN  
Wheel Spacing  
and ADD Off-Side  
Ballast**



**BUCKLE  
the Seat Belt**



**AVOID  
CRUSHING  
Lock-Up Wing**



## Equipment Protective Devices and Recommended Safety Practices

Read manufacturer's operator manual(s) for recommended operating safety practices. Explain the practices to those users or operators who cannot read. **To help prevent serious injury or death to operators and other from alling mower or equipment parts, do the following:**

### **RECOMMENDED SAFETY PRACTICES**

Before working near or underneath lifted mower or equipment parts:

- Use proper equipment shutdown practices before servicing, adjusting, cleaning or unclogging the mower.
- Securely support or block-up raised mower or equipment parts.
- Securely support, block-up or lock-up wings with locking devices on wing type mowers or lower mower or equipment parts to the ground.
- Use transport locks when transporting mower on public roads.

## High Pressure Hydraulic Fluid Leak Hazards and Risks

**A POSSIBLE HIGH PRESSURE FLUID SKIN INJECTION INJURY AND GANGRENE RISK EXISTS FOR MOWER OPERATORS AND OTHERS FROM HIGH PRESSURE HYDRAULIC OR DIESEL OIL LEAK INJECTION INTO THE SKIN.**

**TO AVOID GANGRENE, INJECTED FLUID MUST BE SURGICALLY REMOVED WITHIN A FEW HOURS BY A DOCTOR FAMILIAR WITH THIS TYPE OF INJURY.**

### **RECOMMENDED SAFETY PRACTICES**

Read manufacturer's operator manual(s) for recommended operating safety practices. Explain the practices to those users or operators who cannot read. High pressure fluid pinhole leaks can be almost invisible.

**To help prevent serious injury or death, do the following:**

- Search for leaks with cardboard or wood.
- Do not use hands to check for leaks.
- Relieve system pressure before disconnecting lines.
- Before applying system pressure:
  - Check for damaged lines, pipes, and hoses.
  - Check to insure tight connections.
- Before operating pressurized systems:
  - Purge air from system.
  - Refer to the manufacturer's operator manual(s) for instructions.
  - Explain the procedures to those users or operators who cannot read.

## Tractor Refueling Hazards and Risks

**To avoid serious injury or death from fire during refueling:**

- Shut off engine and ignition.
- Never fill fuel tank near open flames.
- Never smoke while refueling.
- Avoid static electricity sparks by grounding fuel nozzle against tank filler neck.
- Avoid overfilling tank or spilling fuel.
- Clean up any spilled fuel immediately.
- Always replace fuel cap.

**To avoid serious injury or death from engine exhaust fumes:**

- Adequately ventilate enclosed spaces before starting the engine.

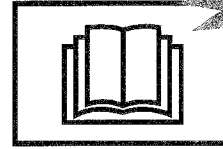

**READ  
Manuals**

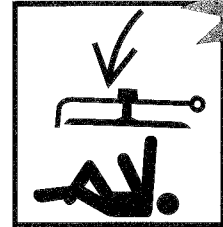

**AVOID  
CRUSHING  
Block-Up or  
Securely Support  
Mower**

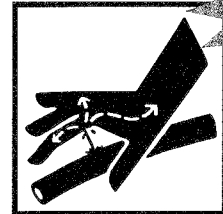

**HIGH  
PRESSURE FLUID  
Can Inject  
into the Body**



**READ  
Manuals**

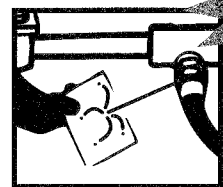

**AVOID  
INJECTION  
Use Cardboard  
Not Hands**



**AVOID  
Fires and  
Explosions**

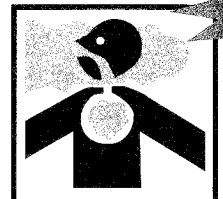

**AVOID  
Exhaust Fumes**



## Follow A Safety Program

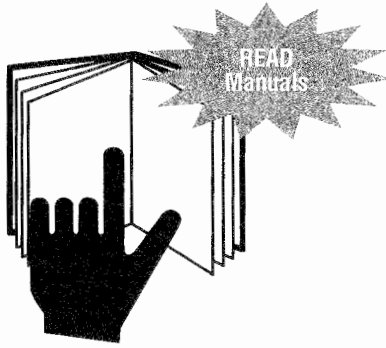

**SAFETY IS IMPORTANT TO RESPONSIBLE OWNERS AND OPERATORS OF TRACTORS AND MOWERS. DO THE FOLLOWING FOR YOUR SAFE MOWING OPERATION:**

### BE A QUALIFIED OPERATOR BY:

- Reading, understanding and obeying the manufacturer's written instructions in operator manual(s) and safety signs on mower and tractor.
- Receiving operational training with mower and tractor.
- Asking your equipment dealer or supervisor to explain things you do not understand.
- Explaining the written instructions in the operator manual(s) and safety signs (decals) on the mower and tractor to those users or operators who cannot read.

## Safety Before Operation

### Know Job Site Safety Rules And Regulations

Ask your supervisor about equipment operation safety rules you will be expected to obey.

#### Some basic rules for your's and others' safety:

- A ROPS and seat belt equipped tractor is required for operator protection during mowing operations.
- Know mower and tractor operating capacity and characteristics.
- Never alter or remove safety equipment.
- Never allow children or unqualified persons to operate mower or tractor.
- Never allow riders on mower or tractor.
- Keep others away from mowing operation.
- Use proper equipment shutdown practice before dismounting tractor.
- Allow all moving parts to stop before making equipment inspections, repairs, or adjustments.
- Securely support or block-up mower before working beneath mower or lifted components.
- Wear personal protective clothing and safety devices issued to you or recommended by the equipment manufacturer.



### Know Tractor And Mower Controls

#### Know the following about your tractor and mower:

- Function, purpose and use of controls.
- Safe operating speeds.
- Safe slope and uneven terrain capabilities.
- Braking and steering characteristics.
- Tractor and mower operating clearances.
- How to stop equipment quickly in an emergency.

## **Use All Available Equipment Safety Devices**

To help keep you and others around you safe:

- Make certain manufacturer's recommended guards, shields and safety signs are installed on equipment and in good condition.
- Keep all protective devices in place and securely fastened.
- **NEVER** operate your equipment with missing, disconnected or damaged safety devices.
- Use ballast and weight required for equipment operational stability.

## **Check The Mower And Tractor Equipment**

**Before beginning your work day:**

- Check for loose, broken, missing or damaged tractor and mower parts.
- Repair or replace these parts when needed.
- Check for proper tractor and mower attachments.
- Check for proper tractor and mower PTO rpm rating match.
- Check mower blades condition. Sharpen or replace per manufacturer's recommendation. Blade modifications, such as welding or hard surfacing cutting edges by welding or straightening bent blades, can reduce blade strength and adversely affect blade properties and safety.
- Check that all guards and shields are in place and that all equipment is in good operating condition. This includes PTO driveline, gearbox and implement guards and shields that are used for operator protection.
- Check for properly latched driveline yoke end locking devices.
- Check for damaged or leaky tractor and mower hydraulic systems.
- Check and read safety signs and warning instructions.
- Explain the safety signs and warning instructions to those users or operators who cannot read.

## **Check The Work Area**

**Inspect, identify and avoid hazardous conditions in the work area:**

- Rough terrain, drop-offs, ditches, potholes steep slopes, stumps, standing water, mud soft soil, slippery conditions, debris and foreign objects.
- Inspect mowing area and remove or mark all foreign objects and debris to be avoided by mower.

**Analyze mowing area to determine:**

- Best and safest mowing procedure.
- Material type and height to be mowed.
- Operating terrain conditions.
- Using forward travel mowing pattern when possible.

## **Look Out For The Safety of Others**

**Before starting equipment:**

- Walk around the equipment.
- Check for anyone under, on or near the equipment.
- Clear everyone from these areas.
- Sound a warning.



**USE ROPS  
and Seatbelt**

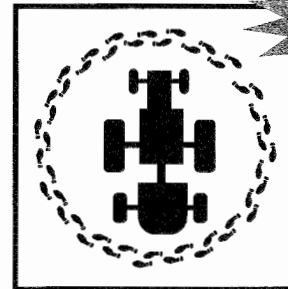

**WALK AROUND  
Inspection**

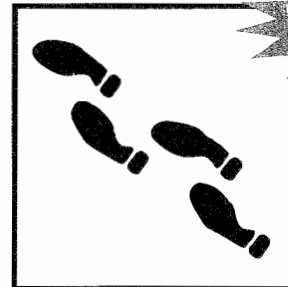

**WALK AROUND  
the Worksite**

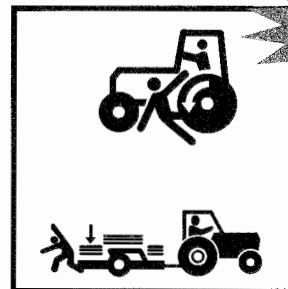

**LOOK OUT  
For Others**

# Safety – Starting & Testing

USE Three Point Contact



USE ROPS and Seatbelt



USE Proper PTO speed

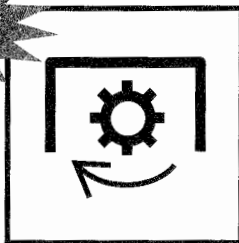

## Mounting Tractor Safety

### Before mounting:

- Clean shoes and wipe hands.

### During mounting and dismounting:

- Use handholds and step plates.
- Never grab steering wheels or controls for handholds.
- Never mount or dismount from a moving tractor.

## Tractor And Mower Controls Safety Test

### Before starting:

- Fasten and adjust seat belt on your ROPS-equipped tractor.
- Check parking brake for engagement.
- Check PTO disengagement.
- Check all controls for Neutral or Park position.
- Warn others in area before starting tractor.
- Follow tractor manufacturer's recommended starting procedures.

### After starting:

- Check all instruments, gauges and indicator lights for normal operation.
- Check all tractor controls, steering and brakes for proper function.
- Repair improperly functioning tractor before using.
- Raise and lower mower for driveline bottoming out or engagement problems.
- Check your equipment for excessive vibration and unusual noises.
- Use proper equipment shutdown practices before inspecting equipment.

## Power Takeoff System And Mower Safety

Tractors with dual-speed (540 or 1000 rpm) shiftable PTO systems.

To avoid serious injury or death from failed parts due to mower over speed:

- Be sure to position PTO selector to mower's rated PTO rpm speed.

Tractors with transmission-driven PTO systems.

A rotary mower will have a significant flywheel effect which may continue to propel a tractor with a transmission-driven PTO system.

The tractor should be equipped and operated as follows:

- Install an over-running clutch.
- Give yourself sufficient maneuvering room and time by anticipating turns, stops and speed reductions.

# Safety – During Operation

## Hitching Mower To Tractor Safety

### Three-point hitch-mounted mower safety:

- Refer to mower and tractor manufacturers' manuals.
- Place tractor's hydraulic power lift (rockshaft) selector lever in down position to avoid unexpected movement.
- Explain the hitching procedures to those users or operators who cannot read.

### Pull-type hitch-mounted mower safety:

- Refer to mower and tractor manufacturers' manuals.
- Attach only to drawbar hitch.
- Do not attach to tractor's rear axle or three-point hitch arms.
- Adjust tractor drawbar length for 540 or 1000 rpm PTO operation.

## Make The Right Start In Mower Safety

Mow only in daylight or good artificial light conditions.

### To avoid serious injury or death from mower thrown objects or blade contact:

- Keep chain shields, flexible or solid deflector shields or discharge chutes in place and in good repair.
- Keep everyone several hundred (300) feet from mowing operation.
- Never direct mower discharge toward anyone.
- Keep hands, feet and other body parts away from rotating parts, blades and discharge openings.
- Do not operate mower in transport position.

### Mower PTO drive engagement:

- Raise mower to maximum cutting height.
- Engage PTO at low engine rpm.
- Increase engine rpm to mower rated rpm PTO speed.
- Lower mower to desired cutting height.
- Stop and shut down immediately if the mower strikes an obstruction.
- Inspect and repair any mower damage before resuming mowing.
- Do not operate mower with severe vibrations or with unusual noise.

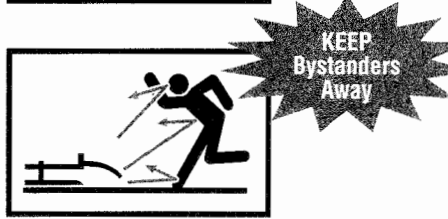
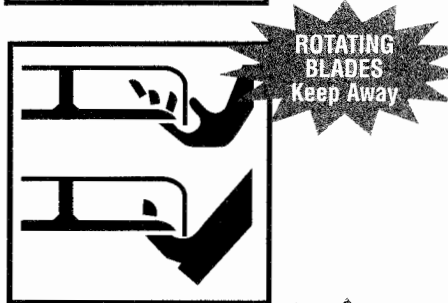
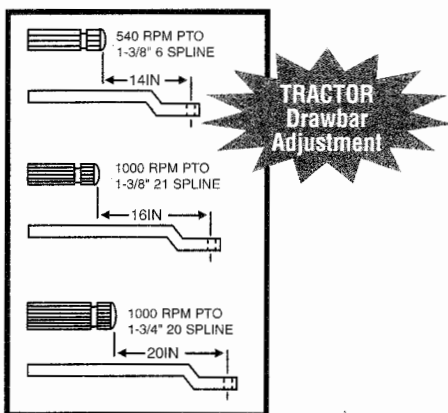

LOOK OUT  
For Others

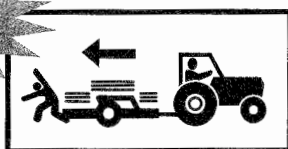

## Mowing In Reverse Safety

Avoid mowing in reverse direction when possible.

Do the following when mowing in reverse direction:

- Check for any persons behind mower before reversing direction.
- Use extreme care when reverse direction mowing.
- Maintain rotary mower front and rear safety shields and flail front shields and rear rollers.

MAINTAIN  
FLAIL  
Rear Roller

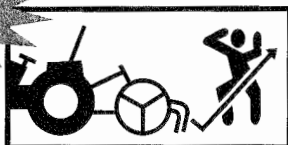

## Mowing Ground Speed

Proper ground speed depends on terrain conditions and grass type, density and height to be cut:

- Normal ground speed range is 2 to 5 mph.
- Slower ground speed for mowing tall, dense grass.
- Faster ground speed for mowing medium height, thin grass and under smooth terrain conditions.
- Use slower ground speed for mowing in rough, sloping or unfamiliar terrain.

USE PROPER  
Ground Speeds

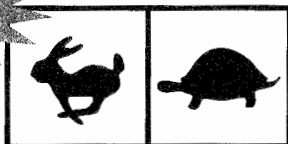

STOP BLADE  
Before  
Unclogging



## Extremely tall grass mowing

- You may need to mow extremely tall grass twice.

First mowing pass:

- Cut grass higher (10-15 inches) to avoid hidden objects.

Second mowing pass:

- Remove debris and objects.
- Cut grass at desired height and 90 degree to the first mowing pass when possible.
- Use proper equipment shutdown practice for your safety before dismounting tractor.

PROVIDE  
Adequate  
Clearance for  
Mower Swing

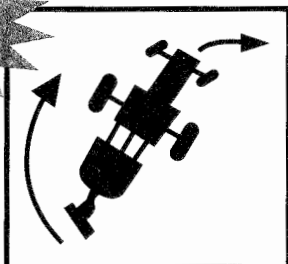

## Watch equipment clearances

Three-point hitch and side mounted mowers have a larger turning arc than pull-type mowers. Allow sufficient clearance for safe turning.

NEVER STAND  
On Mower  
Keep Away

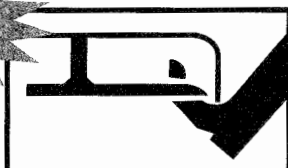

## Under Mount Mower Safety

When mowing with an under mount mower:

- Keep removable discharge chute in place and over discharge opening.
- Never stand on an operating mower housing.
- Distribute grass clipping with discharge chute facing mowed area.
- Use proper equipment shutdown practice before clearing clogged mower or discharge chute.

KEEP CHUTE  
In Place

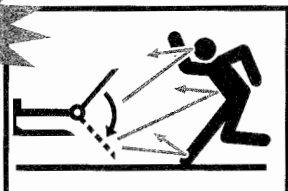

## ***Wing Or Boom Type Mower Overhead Obstruction Hazards and Risks***

Check for overhead obstructions with raised wings or boom-type mowers to avoid serious injury or death by contact with:

- Electrical power lines.
- Low tree limbs.
- Other overhead obstructions.

## ***Wing And Side Mount Mowers Safety***

When mowing with wing and side-mount mowers:

Raised wing positions reduces shielding protection and increases the thrown object and blade contact hazard risks.

To avoid serious injury or death by thrown objects or blade contact from raising and lowering wings during mowing operations:

- Do not mow with bystanders in mowing area.
- Be sure no one is near mower while raising or lowering wings.
- Keep the exposed rotating wing blade time to a practical minimum during a raised wing mowing operations.
- Stop mowing if persons enter into mowing area.
- Only raise wing to clear objects in the mowing path or to match ground slope.
- Disengage wing drive for extended periods of mowing with raised wings.
- Lower raised wing to ground after clearing object or ground slope conditions.
- Allow all mower blades to stop rotating before raising wing sections during other operations.

## ***Ditch Bank Mowing Safety***

Use extreme care when mowing ditch banks. Watch for washouts, eroded areas and mowing obstructions along the ditch banks. Hitting obstructions with side-mount or boom mowers may swerve the tractor's front end toward the ditch.

Raised wing and boom-type mower ditch bank operations may reduce the mower's thrown object shielding effectiveness for the mower operator's protection.

To increase operator protection from thrown objects during ditch bank operations:

- Use enclosed ROPS cabs, special protective enclosures and other operator shielding when performing these operations.
- Inspect mowing area and remove or mark all foreign objects and debris to be avoided by mower.



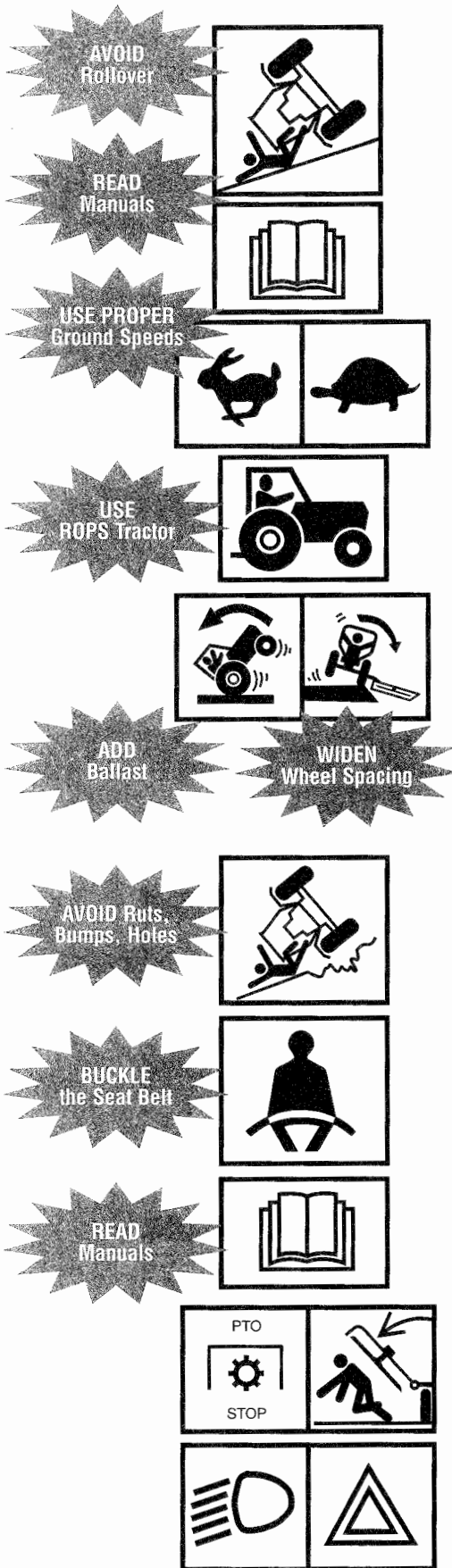

## Mowing Uneven Terrain Safely

The tractor and mower stability is reduced on slopes and uneven terrain.

You can prevent tractor and mower overturns and maintain equipment stability control by:

- Reviewing tractor and mower operator's manuals for operating safety practices on slopes and uneven terrain conditions. Explain the practices to those users and operators who cannot read.
- Avoiding extremely steep slope operations.
- Using extreme care to maintain control over your equipment when operating in these conditions.
- Increasing tractor stability by adding wheel weights and increasing wheel spacing (Refer to tractor operator's manual for recommendations)
- Using ROPS and seat-belt-equipped tractor for operator safety during mowing operations.
- Maintaining minimum ground speed.
- Making wide and gradual turns.
- Avoiding sudden starts, stops, and turns when operating up, down, or across slopes.
- Not raising rear-mount or side-mount mowers or mower wings from the ground during these operations .
- Keeping alert for holes, bumps, ruts, rocks, stumps or other obstructions that could overturn tractor and mower.
- Avoiding slippery ground conditions that could overturn tractor and mower.
- Avoiding tractor and mower "hang up" by diagonal passing through sharp dips and drops.

Use extreme care in maintaining equipment stability during all uneven terrain and slope mowing operations. You are the final judge as to any slope that can be safely negotiated.

## Equipment Road Transporting Safety

If equipment is to be driven on public roads:

- Refer to tractor and mower manufacturers' operator's manuals for instructions.
- Explain the instructions to those users or operators who cannot read.
- Check local regulations for required equipment markings, lights, flashers, etc., while traveling on public roads. Lights are required on mowers that obscure tractor taillights and/or warning lights.

Before transporting on public roads:

- Disengage PTO to mower.
- Raise mower into transport position.
- Lock wings up into transport position with locking devices on wing-type and side-mounted mowers.
- Attach safety chain between pull-type mower and tractor.
- Make sure lights, flashers, reflectors and SMV are in place and visible.
- Check SMV (Slow-Moving Vehicle) emblem for visibility to any rear approaching vehicle.

**While transporting on public roads:**

- Obey all local traffic regulations.
- Approach intersections with caution.
- Observe speed and traffic control signs.
- Avoid panic stops and sharp turns.

**Parking Safety**

**Park equipment at:**

- Designated or out-of-traffic areas.
- Preferably level ground locations.

**Sloping ground parking locations:**

- Position equipment across slope.
- Set parking brakes.
- Lower mower to ground.
- Block tractor wheels.

**Before temporarily parking and leaving disabled equipment near traffic areas:**

- Remove equipment from public roads.
- Set out warning flags
- Use tractor flashers.

**Safety – During Shutdown**

**Use Proper Equipment Shutdown Practices For Your Safety**

Refer to tractor and mower manufacturer’s operator manual(s) for recommend shutdown procedures. Explain the procedures to those users or operators who cannot read.

**Make proper equipment shutdown procedures an important habit to practice. Follow these safety practices before dismanting tractor:**

- Disengage PTO clutch and transmission drive.
- Idle engine for gradual cooling.
- Place the controls in PARK or NEUTRAL.
- Set the parking brake.
- Lower mower to ground.
- Lower wings of wing-type mowers to ground.
- Shut off engine.
- Wait for all moving parts to stop before equipment inspections, adjustments or repairs.
- Relieve hydraulic pressure by moving hydraulic controls several times in all directions.
- Lock ignition and remove key when equipment is to be inspected, repaired, adjusted or unattended.
- Lock anti-vandalism covers and closures when equipment is unattended.
- Dismount carefully maintaining three-point contact.

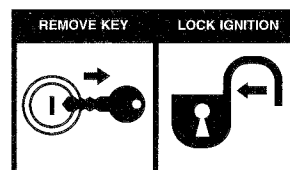
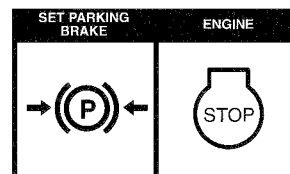
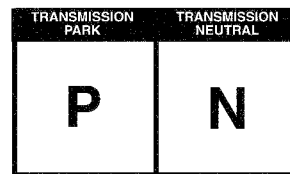
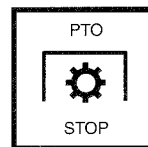
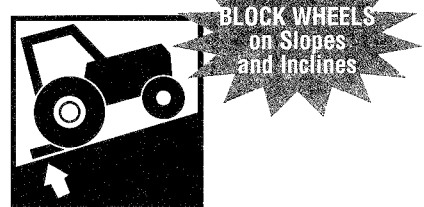
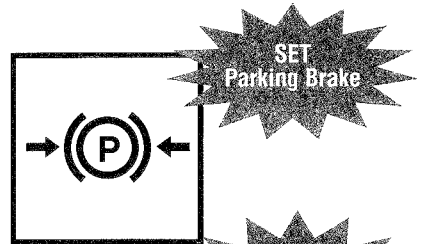
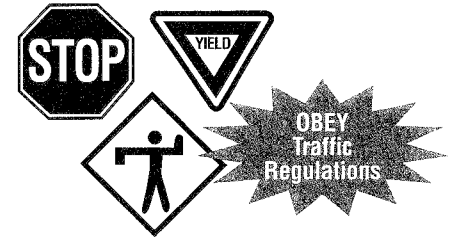



**WAIT For Moving Parts to Stop Before Dismount**



**USE Three Point Contact**



**MAINTAIN Equipment**

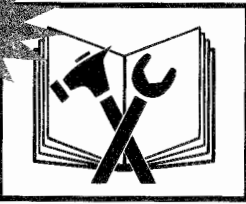

**FOLLOW**

**Maintenance Schedule**



## ***Dismounting Tractor Safely***

### **Before dismounting tractor:**

- Use proper equipment shutdown practice for your safety.
- Lower implement to the ground, stop engine and PTO, set brakes, allow all moving parts to stop, and remove key before dismounting from tractor.
- Never dismount from moving equipment.
- Never jump from machines.
- Dismount carefully.
- Check for slippery steps
- Keep feet and hands away from controls.
- Use handholds and steps during dismount.
- Face machine and use 3 point contact (2 hands, 1 foot or 2 feet, 1 hand).

## ***Safety – During Maintenance***

### ***Maintenance Safety***

**Do the following for your safety before performing any maintenance, repairs or service procedures:**

- Follow proper equipment shutdown practice.
- Wear all the protective clothing and personal safety devices necessary to safely perform the job.
- Refer to your manufacturer's manuals for proper maintenance, repair and service procedures. Explain the procedures to those users and operators who cannot read.

Stored energy sources (electrical, mechanical, hydraulic, pneumatic, chemical, thermal, etc..) must be either locked, blocked, relieved, disconnected, stopped, secured, neutralized, controlled or reduced to a practical minimum before any maintenance, repair or service procedures can be done safely.

**Some basic safety practices to prevent potential injuries from energy releasing sources:**

- Disengage PTO before shutting off engine.
- Place controls in PARK or NEUTRAL before shutting off engine.
- Set parking brake or block wheels.
- Allow all moving parts to stop.
- Lower mower to ground.
- Lower wings to ground on wing-type mowers.
- Shut off tractor engine.
- Lock ignition and remove key.
- Look and listen for evidence of moving parts before opening shields.
- Securely support or block-up mower before working underneath mower or other lifted components.
- Securely support, block-up, or lock-up mower wings with locking devices before working near or underneath a wing-type mower.
- Relieve hydraulic system pressure by moving controls several times in all directions.
- Relieve pressure before disconnecting or disassembling any pressurized system.
- Block or relieve spring pressure before disassembling any spring-loaded mechanism.
- Securely support or block up any elevated machine component before working on it.
- Avoid flames, sparks, or smoking near any fuels.

***Mower Manufacturer Parts and Your Safety***

Most mower manufacturers use special fasteners and specially designed parts to meet mowing operations requirements.

Critical safety-related parts (Self-locking blade bolts, blades, pins, shields or other special items) have specific strength, design and fit requirements for the make and model mower you are using.

**Modifications or repair parts not approved by the mower manufacturer can cause serious safety hazard exposure risk to you and others.**

**TO AVOID SERIOUS INJURY OR DEATH FROM UNAPPROVED PARTS OR MODIFICATIONS:**

- Do not substitute common hardware for self-locking blade bolts or other special part items.
- Do not substitute blades, pins, shields or other critical safety-related parts.
- Do not use grade 5 or 8 bolts to replace grade 2 shear bolts.

***FOLLOW THE SAFETY PRACTICE OF ALWAYS CHECKING THE MOWER FOR PROPER FUNCTION AFTER ALL ADJUSTMENTS REPAIRS OR SERVICE.***

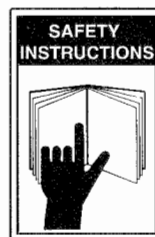
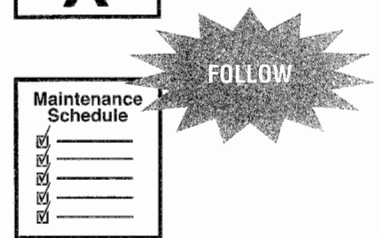
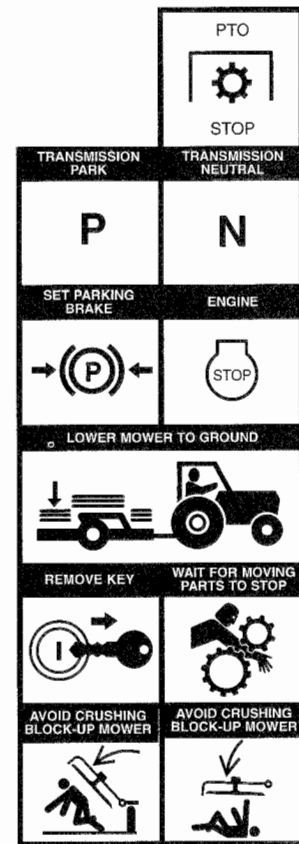

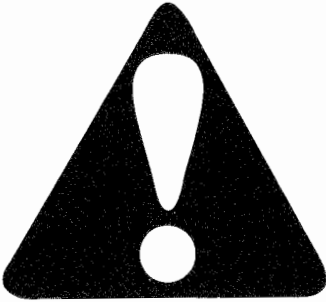

## ***One Final Word***



You have just finished reading the Mower Safety Manual. It is impossible for this manual to cover every potentially hazardous situation you may encounter. But, your knowledge of these safety precautions and your adherence to the basic rules of safety will help build good judgment in all situations. Our objective is to help you develop good safety habits and make you a better mower operator. The mower safety manual, safety precautions and basic rules of safety must be explained to those users or operators who cannot read.

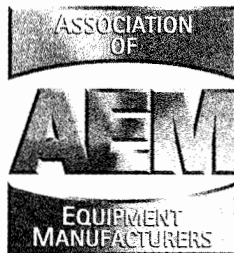

111 E. Wisconsin Avenue • Milwaukee, Wisconsin 53202 U.S.A.  
[www.aem.org](http://www.aem.org)

For information on additional copies of this and  
other safety manuals, call 800-369-2310



# Segadora industrial y agrícola

manual de seguridad

*para operadores  
y mecánicos*

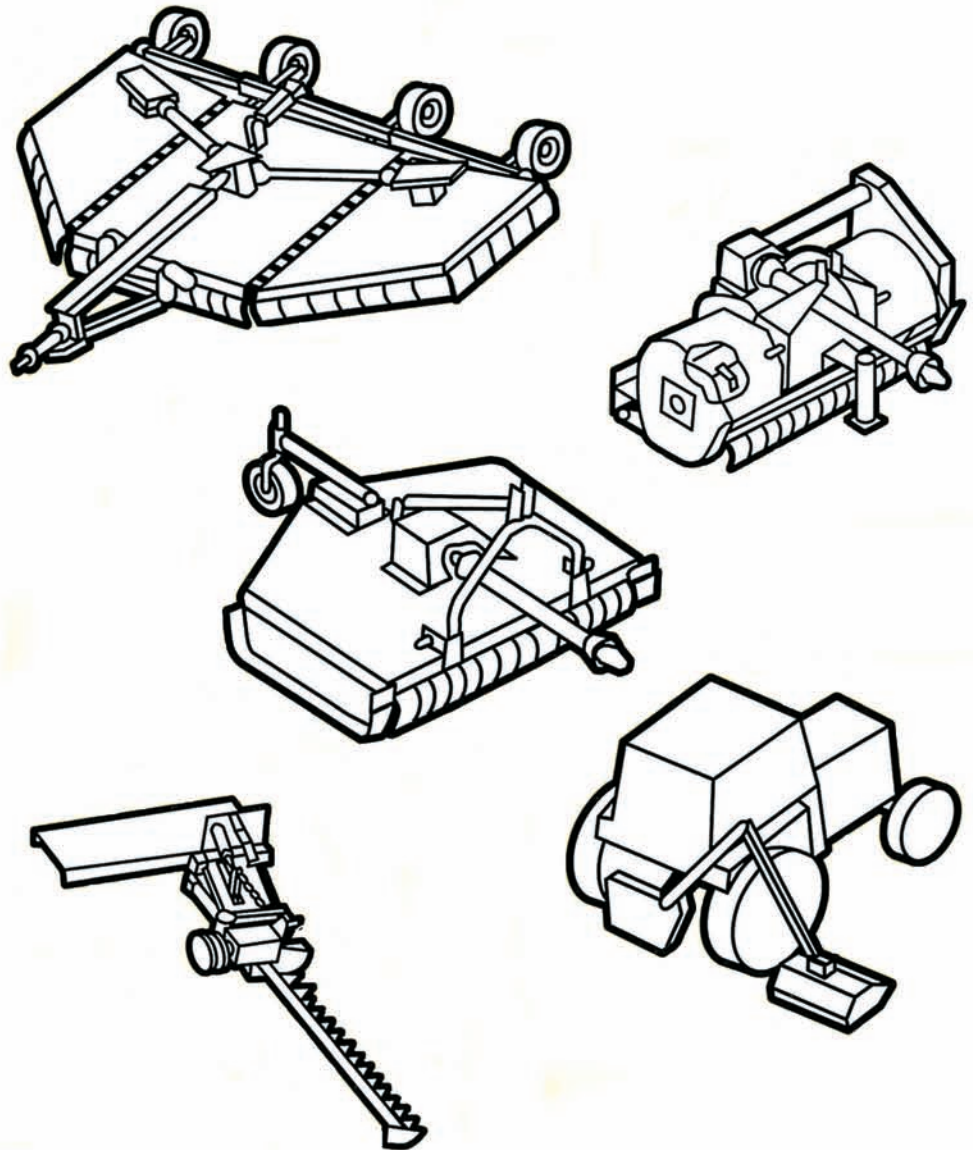

111 E. Wisconsin Avenue • Milwaukee, Wisconsin 53202 U.S.A.  
[www.aem.org](http://www.aem.org)

# Contenido

---

|   |    |
|---|----|
| <b>Reconocimiento</b> .....                         | 2  |
| <b>Introducción</b> .....                           | 3  |
| <b>Palabras para el usuario</b> .....               | 3  |
| <b>Alerta de seguridad</b> .....                    | 4  |
| <b>Segadoras industriales y agrícolas</b> .....     | 4  |
| <b>Sea un operador responsable</b> .....            | 5  |
| <b>Manejo seguro de riesgos y peligros</b> .....    | 6  |
| <b>Cumpla con un programa de seguridad</b> .....    | 11 |
| <b>Seguridad previa a la operación</b> .....        | 11 |
| <b>Seguridad durante el arranque y prueba</b> ..... | 13 |
| <b>Seguridad durante la operación</b> .....         | 14 |
| <b>Seguridad durante la parada</b> .....            | 18 |
| <b>Seguridad durante el mantenimiento</b> .....     | 19 |
| <b>Palabra final</b> .....                          | 21 |

## Reconocimiento

---

Deseamos extender nuestro reconocimiento a los miembros de del Association of Equipment Manufacturers por sus contribuciones para la preparación de este manual de seguridad.

### Derechos de autor

© 2000 Equipment Manufacturers Institute. Todos los derechos reservados. Revisado 08.2003

# Introducción

---

El propósito de este manual de seguridad es señalar algunas de las situaciones básicas de seguridad que pueden ocurrir durante la operación y mantenimiento de su máquina y sugerir los métodos posibles para tratar estas situaciones. Este manual NO es un sustituto de el (los) manual(es) del fabricante.

Pueden ser necesarias algunas precauciones adicionales, o algunas instrucciones no pueden aplicar, dependiendo del equipo, dispositivos de fijación, y las condiciones del lugar de trabajo o del área en que se realiza el servicio. El fabricante no tiene control directo sobre las aplicaciones, operación, inspección, lubricación o mantenimiento de la máquina. Por lo tanto, es **SU** responsabilidad practicar buenas medidas de seguridad en estas áreas.

La información proporcionada en este manual sirve como complemento de los detalles de información específicos de su máquina que están incluidos en el (los) manual(es) del fabricante. La información adicional que pueda afectar la operación segura de su máquina puede estar incluida en las etiquetas de seguridad o en los requisitos del seguro, programas de seguridad del empleador, códigos de seguridad, leyes locales del estado/provincia y leyes nacionales, reglas y reglamentos.

**IMPORTANTE:** si usted no tiene el (los) manual(es) del fabricante de su máquina específica, obtenga un manual de reemplazo con su empleador, distribuidor de equipo o el fabricante de su máquina. Mantenga este manual de seguridad y el (los) manual(es) del fabricante con su máquina.

## Palabras para el usuario

---

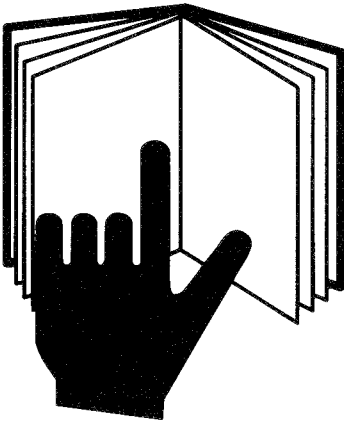

Usted tiene la responsabilidad de leer y comprender este manual de seguridad y el (los) manual(es) del fabricante, antes de operar esta máquina. Este manual de seguridad lo guía paso a paso a lo largo de su día de trabajo. El manual de seguridad, el (los) manual(es) del fabricante, avisos de seguridad (calcomanías) y precauciones de seguridad, deben explicarse a los usuarios u operadores que no puedan leer el material.

Adicionalmente al diseño y configuración del equipo el **CONTROL DEL PELIGRO** y la **PREVENCIÓN DE ACCIDENTES** dependen de la conciencia, preocupación, prudencia y capacitación adecuada de los propietarios y operadores durante la operación, transporte, mantenimiento y almacenamiento del equipo.

Recuerde que **USTED** es la clave para mantener la seguridad. Las buenas prácticas de seguridad no lo protegen solamente a usted sino que también a las personas que lo rodean. Estudie este manual y el (los) manual(es) del fabricante para su máquina específica. Hágalos una parte integral de su programa de seguridad. Recuerde que este manual de seguridad está escrito únicamente para segadoras industriales y agrícolas.

**Practique todas las precauciones de seguridad usuales y acostumbradas en el trabajo y más que todo – recuerde que la seguridad depende de USTED. Solamente USTED puede evitar las lesiones graves o la muerte debidas a prácticas inseguras.**

# Advertencia de seguridad

## Símbolo

Este símbolo de alerta de seguridad significa:

**“¡ATENCIÓN! ¡MANTÉNGASE ALERTA! ¡SU SEGURIDAD ESTÁ INVOLUCRADA!”**



El símbolo de alerta de seguridad identifica los mensajes de seguridad importantes en el equipo, en los avisos de seguridad, en los manuales y en otros lugares. Cuando usted vea este símbolo, esté alerta a la posibilidad de muerte o lesiones. Siga las instrucciones en el aviso de seguridad.

## Palabras de señales

Las palabras de señales son palabras específicas que regularmente se encontrarán en las calcomanías de seguridad en este equipo o en otros equipos en el lugar de trabajo. Estas palabras tienen el objetivo de alertar a la persona que las vea de la presencia y el grado relativo de un riesgo.



Esta palabra de señal indica una situación de riesgo inminente que si no es evitado podrá resultar en la muerte o lesiones graves.



Esta palabra de señal indica una situación potencialmente riesgosa que si no se evita podría resultar en la muerte o lesiones graves.



Esta palabra de señal indica una situación potencialmente riesgosa que si no se evita podría resultar en lesiones menores o moderadas.

- LOS ACCIDENTES PUEDEN LISIAR Y CAUSAR LA MUERTE.
- LOS ACCIDENTES SON COSTOSOS.
- LOS ACCIDENTES PUEDEN EVITARSE.

# Segadoras industriales y agrícolas

Es una segadora para cortar pasto, triturar residuos de cultivos, cortar maleza para la limpieza de terrenos, vías navegables, derechos de paso, cortes en los bordes de los caminos o carreteras.

## TIPOS DE SEGADORAS INDUSTRIALES Y AGRÍCOLAS:

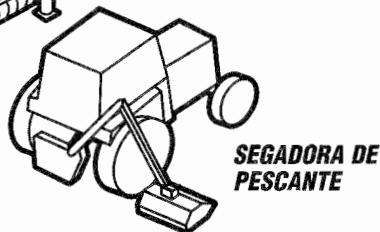
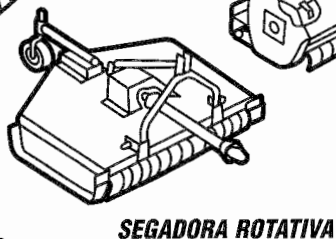
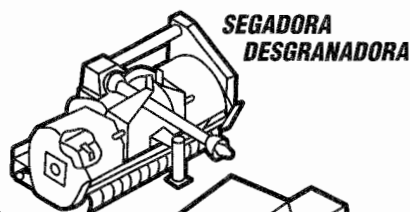



# Sea un operador responsable



Para la operación segura de su equipo usted debe ser un operador responsable. Un operador responsable debe comprender claramente las instrucciones escritas proporcionadas por el fabricante ser capacitado – incluyendo la operación real del equipo y el conocimiento de las reglas y reglamentos de seguridad del lugar de trabajo.

Las medicinas y el alcohol pueden y afectarán el estado de alerta y coordinación del operador, por lo tanto, afectarán la habilidad del operador para operar el equipo en forma segura. Un operador **NUNCA** debe usar medicinas que puedan afectar su estado de alerta, juicio y coordinación; ni beber alcohol mientras opera equipo motorizado incluyendo tractores y segadoras. Un operador que use medicamentos por prescripción médica o de venta libre debe consultar con un médico profesional para conocer sobre cualquier efecto secundario que podría limitar su habilidad para operar este equipo en forma segura. **NUNCA** permita que alguien opere este equipo cuando estén afectados su estado de juicio alerta o de coordinación.

## Protéjase usted mismo

Use toda la ropa protectora y los dispositivos de seguridad personal que se le proporcionen o que sean los indicados para las condiciones de trabajo.

### Usted puede necesitar:

- Casco protector
- Zapatos de seguridad
- Anteojos de seguridad con protección lateral, gafas protectoras o protector facial
- Guantes extrafuertes
- Protección auditiva
- Ropa reflectora
- Equipo para clima húmedo
- Respirador o máscara filtrante

Use ropa apropiada para las condiciones del trabajo.

Siempre conozca cómo obtener ayuda en caso de una emergencia. Conozca donde encontrar y cómo usar los equipos de primeros auxilios y el extintor de incendios/sistema de supresión de incendios.



**Manténgase alerta. Evite los accidentes.  
No conozca la seguridad en la forma más difícil.**

# Manejo seguro de riesgos y peligros

Adicionalmente al diseño y configuración del equipo, el **CONTROL DEL PELIGRO** y la **PREVENCIÓN DE ACCIDENTES** dependen de la conciencia, preocupación, prudencia y capacitación adecuada de los propietarios y operadores durante la operación, transporte, mantenimiento y almacenamiento del equipo.

**EL MANEJO SEGURO DE RIESGOS Y PELIGROS ES UN ELEMENTO ESENCIAL PARA LOS PROPIETARIOS Y OPERADORES RESPONSABLES DE TRACTORES Y SEGADORAS.**

**REVISE EL MANEJO SEGURO DE LOS PELIGROS Y RIESGOS ENUMERADOS A CONTINUACIÓN.**

## ***Peligro de objetos despididos***

EXISTE LA POSIBILIDAD DEL RIESGO DE LESIONES A LOS OPERADORES Y TRANSEÚNTES CAUSADAS POR OBJETOS DESPIDIDOS DURANTE LA OPERACIÓN DE LA SEGADORA POR LOS SIGUIENTES:

OBJETOS (PIEDRAS, ESCOMBROS, HOJAS ROTAS DE LA SEGADORA, PERNOS DE LA HOJA, CABLES, CADENAS, ALAMBRE, ETC.) DESPIDIDOS POR LA SEGADORA.

## ***Dispositivos protectores del equipo y prácticas de seguridad recomendadas***

La cubierta de la segadora y los dispositivos protectores no pueden evitar que escapen todos los objetos o desechos del área cerrada de la hoja en todas las condiciones de segado. Es posible que los objetos escapen y se desplacen cientos de pies (300 [100 m]).

### **PRÁCTICAS DE SEGURIDAD RECOMENDADAS**

Lea los manuales del operador del fabricante para conocer las prácticas de seguridad recomendadas durante la operación. Explique las prácticas a los usuarios u operadores que no puedan leer.

**PARA AYUDAR A EVITAR LESIONES GRAVES O LA MUERTE CAUSADAS POR OBJETOS QUE GOLPEEN AL OPERADOR U OTRAS PERSONAS HAGA LO SIGUIENTE:**

### **SEGURIDAD DE TRANSEÚNTES**

- Mantenga a los transeúntes a varios cientos de pies (300 [100 m]) del área segada.

### **SEGURIDAD PROPORCIONADA POR LOS DISPOSITIVOS PROTECTORES DEL EQUIPO**

Para contener, desviar o reducir los objetos despididos del área cerrada de la hoja:

- Mantenga la cadena, blindajes deflectores flexibles o sólidos colocados en la parte delantera y trasera de la cubierta de la segadora, en su lugar y en buen estado de funcionamiento.
- No opere el equipo con los blindajes para objetos despididos dañados o sin que estén colocados en su lugar.

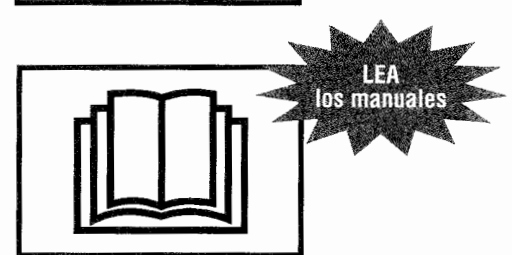

## SEGURIDAD DEL OPERADOR

La operación de las segadoras con las alas levantadas, de montaje lateral y pescante, pueden reducir la efectividad del blindaje para proteger al operador contra los objetos despedidos de la segadora.

**Haga lo indicado a continuación para aumentar la protección del operador contra los objetos despedidos durante las operaciones de segado:**

- Use cabinas cerradas con una estructura de protección contra vuelcos (ROPS), cubiertas protectoras especiales, mallas u otros dispositivos para proteger al operador cuando efectúa estas operaciones.

### **SOBREPASAR LAS VELOCIDADES RECOMENDADAS PARA LA TOMA DE FUERZA (PTO)**

No sobrepase las velocidades recomendadas por el fabricante para la toma de fuerza (PTO).

**Las velocidades excesivas de la toma de fuerza (PTO) pueden causar:**

- Fallo de la hoja
- Escape de objetos a velocidad alta u hojas rotas despedidas del área cerrada de la hoja de la segadora.
- Fallos potenciales de la línea de transmisión de 540 rpm cuando se opera a velocidades de 750 a 1000 rpm.

### **OTRAS PRÁCTICAS DE SEGURIDAD:**

- Nunca debe operar la segadora con hojas rotas, dobladas, faltantes o que estén extremadamente desgastadas.
- Antes de segar retire los desechos y objetos extraños para evitar que sean recogidos y despedidos por la segadora.
- No debe operar la segadora durante el transporte o en posición de ala levantada.

### **PRÁCTICAS DE MANTENIMIENTO RECOMENDADAS**

Lea los manuales del operador del fabricante para conocer sobre la inspección y mantenimiento de las defensas de la cadena y blindaje deflector flexible o sólido:

- Reemplace las defensas desgastadas o dañadas y los demás blindajes antes de segar.
- Use solamente las defensas y blindajes de reemplazo del fabricante. Otras defensas o blindajes pueden no encajar, o los materiales pueden no ser adecuados para cumplir con los requisitos de resistencia del equipo.
- Reemplace las calcomanías desgastadas o dañadas y las instrucciones de advertencia.
- Explique las instrucciones de inspección y mantenimiento a los usuarios u operadores que no puedan leer.

USE cabinas cerradas con una estructura protectora contra vuelcos (ROPS) o cubiertas protectoras

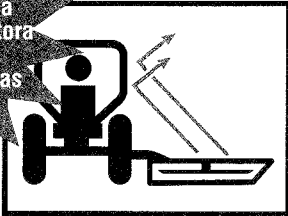

USE la velocidad apropiada de la toma de fuerza (PTO)

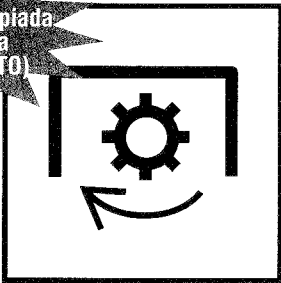

DÉ MANTENIMIENTO a su equipo

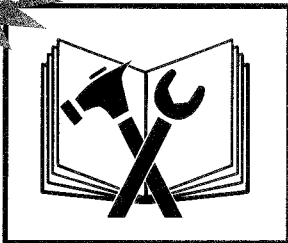

# ***Peligros y riesgos de las hojas rotativas y línea de transmisión***

EXISTE EL RIESGO DE POSIBLES LESIONES A LOS OPERADORES DE LA SEGADORA Y TRANSEÚNTES DURANTE LAS OPERACIONES DE SEGADO CAUSADAS POR LO SIGUIENTE:

- CONTACTO DEL CUERPO CON LAS HOJAS ROTATIVAS.
- ENREDO DEL CUERPO CON LAS LÍNEAS DE TRANSMISIÓN Y PIEZAS ROTATIVAS.

## ***Dispositivos protectores del equipo y prácticas de seguridad recomendadas***

### **PRÁCTICAS DE SEGURIDAD RECOMENDADAS**

Lea los manuales del operador del fabricante para conocer las prácticas de seguridad recomendadas. Explique las prácticas a los usuarios u operadores que no puedan leer. Para evitar el riesgo de lesiones graves o la muerte causadas por el contacto con la hoja en movimiento, línea de transmisión o enredo de los operadores u otras personas haga lo siguiente:

#### **SEGURIDAD DE TRANSEÚNTES**

- No debe operar cerca de transeúntes.
- Mantenga a otras personas a varios cientos de pies (300 [100 m]) del área de segado.

#### **PRÁCTICAS DE SEGURIDAD DEL OPERADOR**

- No permita pasajeros en el tractor o segadora. Asegúrese el cinturón de seguridad durante el segado.
- Use la práctica de parada del equipo apropiada antes de dar servicio, ajustar, limpiar o eliminar las obstrucciones de la segadora.
- Manténgase alejado de las hojas rotativas, piezas y líneas de transmisión.
- Nunca arranque el motor del tractor mientras esté de pie al lado del equipo.
- Solamente arranque el motor del tractor cuando esté sentado en el asiento del operador con el cinturón de seguridad abrochado.

#### **PRÁCTICAS DE SEGURIDAD RECOMENDADAS PARA DEFENSAS Y BLINDAJES DE LA LÍNEA DE TRANSMISIÓN**

- Mantenga las líneas de transmisión y otros blindajes colocados y en buen estado.
- No debe operar la segadora cuando las defensas, defensas de la línea de transmisión u otros blindajes hagan falta o estén dañados.

#### **PRÁCTICAS DE SEGURIDAD RECOMENDADAS**

Lea los manuales del operador del fabricante para conocer las instrucciones sobre defensas, defensas de la línea de transmisión y otros blindajes:

- Reemplace las defensas, defensas de la línea de transmisión y otros blindajes desgastados o dañados antes de segar.
- Use solamente defensas y blindajes de reemplazo hechas por el fabricante. Otras defensas o blindajes pueden no encajar o ser de materiales inadecuados que no cumplan con los requisitos de resistencia del equipo.
- Reemplace las calcomanías e instrucciones de advertencia desgastadas o dañadas.
- Explique las instrucciones de inspección y mantenimiento a los usuarios u operadores que no puedan leer.



**EVITE enredarse**



**EVITE las piezas rotativas**



**LEA los manuales**



**ASEGÚRESE el cinturón de seguridad**



**NO LLEVE PASAJEROS**



**EVITE el ser atropellado**



**DÉ MANTENIMIENTO a su equipo**

**EVITE vuelcos**

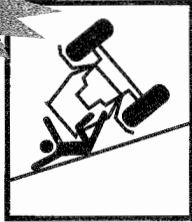

**USE la estructura contra vuelcos (ROPS) del tractor**



**LEA los manuales**

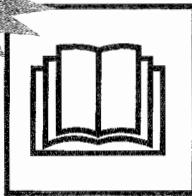

**AGREGUE balasto**



**AUMENTE el espacio entre las ruedas y AGREGUE balasto en el lado contrario**



**ASEGURESE el cinturón de seguridad**



**EVITE EL APLASTAMIENTO asegure el ala**



## ***Peligros y riesgos de rodamiento o vuelco del tractor y segadora***

EXISTE UN RIESGO DE LESIONES POSIBLES AL OPERADOR POR RODAMIENTO O VUELCO DE LA SEGADORA DURANTE LAS OPERACIONES DE SEGADO POR LO SIGUIENTE:

- TERRENO ACCIDENTADO, PENDIENTES INCLINADAS, AGUJEROS, BACHES, SURCOS, PIEDRAS, TRONCOS U OTRAS OBSTRUCCIONES QUE PODRÍAN VOLCAR EL TRACTOR Y SEGADORA.
- VELOCIDADES ABSOLUTAS EXCESIVAS PARA ESTAS CONDICIONES DE TERRENO.

### ***Dispositivos protectores del equipo y prácticas de seguridad recomendadas***

Cuando sea posible, retire los troncos, piedras, etc., o márquelos claramente con las demás obstrucciones para evitar vuelcos, averías y condiciones de conducción peligrosas. Tenga extremo cuidado para mantener el control sobre el equipo cuando opere en terrenos con estas condiciones.

#### **ESTRUCTURAS CONTRA VUELCO (ROPS) RECOMENDADAS PARA TRACTORES**

Un tractor equipado con una estructura contra vuelcos (ROPS) o cabina ROPS cerrada y cinturón de seguridad para la seguridad del operador, es esencial para la protección adicional del operador, cuando opera en terrenos con estas condiciones

#### **AJUSTES RECOMENDADOS PARA LA ESTABILIDAD DEL TRACTOR**

Lea el manual del operador del tractor para conocer los ajustes para aumentar la estabilidad del tractor:

- Agregue pesas o balasto a las ruedas delanteras y traseras.
- Ajuste el espacio entre las ruedas al ancho máximo.
- Agregue contra balasto en el lado contrario a las segadoras de montaje lateral y de pescante.
- Explique los ajustes a los usuarios u operadores que no puedan leer.

### ***PRÁCTICAS DE SEGURIDAD RECOMENDADAS***

Lea los manuales del operador del fabricante para conocer las prácticas de seguridad de operación recomendadas. Explique las prácticas a los usuarios u operadores que no puedan leer. **Para evitar lesiones graves o la muerte del operador por el vuelco del tractor y segadora, haga lo siguiente:**

- Abroche firmemente el cinturón de seguridad cuando seque con tractores equipados con una estructura contra vuelcos (ROPS).
- Evite la velocidad absoluta excesiva de acuerdo con las condiciones del terreno.
- Evite los arranques, paradas y virajes repentinos cuando opere subiendo, bajando o atravesando pendientes.
- Evite las condiciones de terreno resbaloso.
- Haga virajes anchos y graduales.
- Planifique segar cuesta abajo en pendientes inclinadas para evitar los vuelcos.

## ***Peligros y riesgos de aplastamiento por una segadora o piezas desprendidas***

EXISTE EL RIESGO DE UNA LESIÓN POR APLASTAMIENTO PARA LOS OPERADORES Y OTRAS PERSONAS DURANTE LAS OPERACIONES DE SEGADO DEBIDO A LO SIGUIENTE:

- SEGADORA O EQUIPO DESPRENDIDO DEBIDO A FALLO DEL SISTEMA HIDRÁULICO.
- FALLO EN DAR SOPORTE, BLOQUEAR O ASEGURAR COMPLETAMENTE LA SEGADORA O PIEZAS DEL EQUIPO.

## Dispositivos protectores del equipo y prácticas de seguridad recomendadas

Lea los manuales del operador del fabricante para conocer las prácticas de seguridad de operación recomendadas. Explique las prácticas a los usuarios u operadores que no puedan leer. **Para ayudar a evitar lesiones serias o la muerte de los operadores y otras personas causadas por la caída de la segadora o piezas de equipo, haga lo siguiente:**

### **PRÁCTICAS DE SEGURIDAD RECOMENDADAS**

Antes de trabajar cerca o debajo de la segadora o piezas de equipo en posición levantada:

- Use la práctica de parada del equipo apropiada antes de dar servicio, ajustar, limpiar o eliminar las obstrucciones de la segadora.
- Soporte o coloque bloques firmemente debajo de la segadora o piezas de equipo.
- En las segadoras de tipo ala coloque bloques o asegure firmemente las alas con los seguros o baje al suelo la segadora o piezas del equipo.
- Use los seguros de transporte cuando transporte la segadora en caminos públicos.

### ***Peligros y riesgos por la fuga de fluido hidráulico a presión alta***

EXISTE UN RIESGO PARA LOS OPERADORES DE SEGADORAS Y OTRAS PERSONAS DE UNA POSIBLE INYECCIÓN DE FLUIDO A PRESIÓN ALTA O GANGRENA CAUSADA POR LA INYECCIÓN EN LA PIEL DE ACEITE HIDRÁULICO O DIESEL.

PARA EVITAR LA GANGRENA, EL FLUIDO INYECTADO DEBE SER ELIMINADO QUIRÚRGICAMENTE EN POCAS HORAS, POR UN MÉDICO FAMILIARIZADO CON ESTE TIPO DE LESIÓN.

### **PRÁCTICAS DE SEGURIDAD RECOMENDADAS**

Lea los manuales del operador del fabricante para conocer las prácticas de seguridad recomendadas. Explique las prácticas a los usuarios u operadores que no puedan leer. Las fugas de fluido a presión alta por agujeros minúsculos pueden ser casi invisibles.

**Para ayudar a evitar lesiones serias o la muerte haga lo siguiente:**

- Busque las fugas con pedazos de cartón o madera.
- No use las manos para verificar la presencia de fugas.
- Descargue la presión del sistema antes de desconectar los conductos.
- Antes de aplicar presión al sistema:
  - Revise que los conductos, tuberías y mangueras no estén dañados.
  - Revise que las conexiones estén apretadas.
- Antes de operar los sistemas presurizados:
  - Descargue el aire del sistema.
  - Haga referencia al (los) manual(es) del operador del fabricante para obtener instrucciones.
  - Explique los procedimientos a los usuarios u operadores que no puedan leer.

### ***Peligros y riesgos durante el llenado de combustible del tractor***

Para evitar las lesiones serias o la muerte por incendio durante el llenado:

- Apague el motor y la ignición.
- Nunca llene el tanque de combustible cerca de llamas descubiertas.
- Nunca fume mientras llena combustible.
- Evite las chispas causadas por la electricidad estática poniendo a tierra la boquilla del combustible contra el cuello de llenado del tanque.
- Evite sobrellenar el tanque o derramar el combustible.
- Limpie inmediatamente el combustible derramado.
- Siempre vuelva a colocar la tapa del combustible.

Para evitar lesiones serias o la muerte causadas por las emanaciones del escape del motor:

- Ventile adecuadamente los espacios cerrados antes de arrancar el motor.



LEA los manuales



EVITE EL APLASTAMIENTO coloque bloques o soportes seguros en la segadora



FLUIDO A PRESIÓN ALTA puede inyectarse en el cuerpo



LEA los manuales

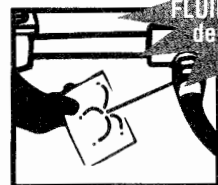

EVITE LA INYECCIÓN DE FLUIDO use un pedazo de cartón, no use las manos



EVITE los incendios y las explosiones

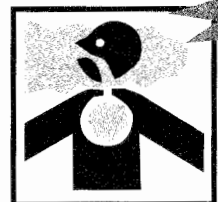

EVITE las emanaciones del escape

## Cumpla con un programa de seguridad



LA SEGURIDAD ES IMPORTANTE PARA LOS PROPIETARIOS Y OPERADORES RESPONSABLES DE TRACTORES Y SEGADORAS. HAGA LO SIGUIENTE PARA SU SEGURIDAD DURANTE LA OPERACIÓN DE SEGADO:

### SEA UN OPERADOR CAPACITADO HACIENDO LO SIGUIENTE:

- Leyendo, comprendiendo y obedeciendo las instrucciones escritas del fabricante en el (los) manual(es) del operador y avisos de seguridad en la segadora y tractor.
- Recibiendo capacitación operativa para la segadora y tractor.
- Solicitando a su distribuidor de equipo o supervisor que le explique lo que usted no comprende.
- Explicando las instrucciones escritas en el (los) manual(es) del operador y avisos de seguridad (calcomanías) en la segadora y tractor a los usuarios u operadores que no puedan leer.

## Seguridad previa a la operación

### Conozca las reglas y reglamentaciones de seguridad del lugar de trabajo

Pregunte a su supervisor sobre las reglas de seguridad de operación del equipo que usted deberá obedecer.

#### Algunas reglas para su seguridad y la de los demás:

- Un tractor equipado con una estructura contra vuelcos (ROPS) es necesario para la protección del operador durante las operaciones de segado.
- Conozca la capacidad y características de operación de la segadora y tractor.
- Nunca altere o desmonte el equipo de seguridad.
- Nunca permita que niños o personas no capacitadas operen una segadora o tractor.
- Nunca permita pasajeros en la segadora o tractor.
- Mantenga a otras personas alejadas de la operación de segado.
- Use la práctica apropiada para parar el equipo antes de bajarse del tractor.
- Permita que se detengan todas las piezas móviles antes de efectuar inspecciones, reparaciones o ajustes al equipo.
- Soporte o coloque bloques firmemente debajo de la segadora antes de trabajar debajo de la segadora o componentes elevados.
- Use la ropa protectora y dispositivos de seguridad personal que le han sido asignados o recomendados por el fabricante del equipo.



### Conozca los controles del tractor y segadora

#### Conozca lo siguiente sobre su tractor y segadora:

- Función, propósito y uso de los controles.
- Velocidades seguras de operación.
- Capacidad para operar en forma segura en pendientes y terreno accidentado.
- Características de frenado y dirección.
- Espacios libres necesarios para la operación del tractor y segadora.
- Cómo detener rápidamente el equipo cuando haya una emergencia.



## Use todos los dispositivos de seguridad del equipo disponibles

Para ayudar a mantener su seguridad y la de las personas que lo rodean:

- Asegúrese de que las defensas, blindajes y avisos de seguridad recomendados por el fabricante están instalados en el equipo y en buen estado.
- Mantenga todos los dispositivos protectores en su lugar y abrochados firmemente.
- **NUNCA** debe operar su equipo con los dispositivos de seguridad sin colocar, desconectados o dañados.
- Use el balasto y peso requerido para la estabilidad operativa del equipo.

## Inspeccione el equipo de la segadora y tractor

Antes de comenzar su día de trabajo:

- Revise que no haya piezas del tractor y segadora que estén sueltas, rotas, dañadas o que no estén colocadas en su lugar.
- Repare o reemplace estas piezas cuando sea necesario.
- Verifique que los implementos del tractor y segadora sean los apropiados.
- Verifique que sean iguales las rpm de régimen de la toma de fuerza (PTO) a las del tractor y de la segadora.
- Revise el estado de las hojas de la segadora. Afile o reemplace de acuerdo con las recomendaciones del fabricante. Las modificaciones a las hojas como soldadura o endurecimiento de los bordes cortantes con soldadura o enderezado de las hojas dobladas, pueden reducir la resistencia de las hojas y afectar adversamente las propiedades y seguridad de las hojas.
- Verifique que todas las defensas y blindajes estén colocados en su lugar y que todo el equipo esté en buen estado de funcionamiento. Esto incluye la línea de transmisión de la toma de fuerza (PTO), caja de engranajes, defensas y blindajes del implemento que sirven para la protección del operador.
- Verifique que la horqueta de la línea de transmisión y los dispositivos de seguro estén correctamente asegurados.
- Verifique que los sistemas hidráulicos del tractor y segadora no estén dañados ni tengan fugas.
- Revise y lea los avisos de seguridad y las instrucciones de advertencia.
- Explique los avisos de seguridad e instrucciones de advertencia a los usuarios u operadores que no puedan leer.

## Inspeccione el área de trabajo

Inspeccione, identifique y evite las condiciones peligrosas en el área de trabajo:

- Terreno accidentado, bajadas escarpadas, zanjas, agujeros, pendientes inclinadas, troncos, agua estancada, suelo de lodo suave, condiciones resbalosas, desechos y objetos extraños.
- Inspeccione el área de segado y elimine o marque todos los objetos extraños y desechos que debe evitar con la segadora.

Analice el área de segado para establecer:

- El mejor y más seguro procedimiento de segado.
- Tipo de material y altura de segado.
- Estado del terreno de operación.
- El uso de un patrón de segado de desplazamiento hacia delante siempre que sea posible.

## Verifique la seguridad de las demás personas

Antes de arrancar el equipo:

- Camine alrededor del equipo.
- Verifique que no haya nadie debajo, sobre o cerca del equipo.
- Aleje a todas las personas de estas áreas.
- Haga sonar una alarma.



USE UNA ESTRUCTURA CONTRA VUELCOS (ROPS) y el cinturón de seguridad

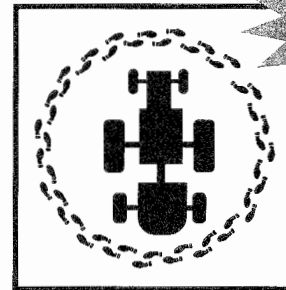

CAMINE ALREDEDOR para inspeccionar

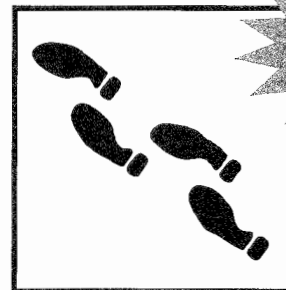

CAMINE ALREDEDOR del lugar de trabajo

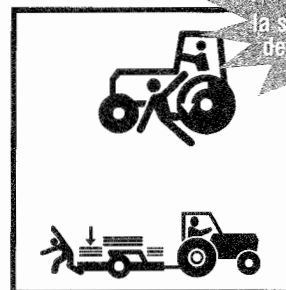

VERIFIQUE la seguridad de las demás personas



# Seguridad durante el arranque y prueba

USE  
el contacto de  
tres puntos



USE UNA  
ESTRUCTURA  
CONTRA VUELCOS  
(ROPS) y el  
cinturón de  
seguridad



USE la  
velocidad  
correcta de la  
toma de fuerza  
(PTO)

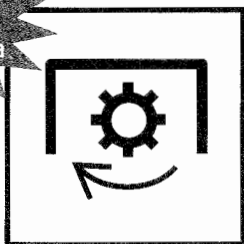

## Seguridad durante la subida al tractor

### Antes de subir:

- Límpiense los zapatos y las manos.

### Durante la subida y la bajada del tractor:

- Use las asas y placas de los escalones.
- Nunca utilice los volantes de dirección o controles como asas.
- Nunca suba ni baje de un tractor en movimiento.

## Prueba de seguridad de los controles del tractor y segadora

### Antes del arranque:

- Ajuste y abroche el cinturón de seguridad en su tractor equipado con una estructura contra vuelcos (ROPS).
- Verifique que el freno de estacionamiento esté enganchado.
- Verifique que desenganche la toma de fuerza (PTO).
- Verifique que todos los controles estén en la posición de punto muerto (N) o de estacionamiento (P).
- Advierta a las demás personas presentes en el área antes de arrancar el tractor.
- Cumpla con los procedimientos de arranque recomendados por el fabricante del tractor.

### Después del arranque:

- Revise que todos los instrumentos, indicadores y luces indicadoras funcionen normalmente.
- Revise que todos los controles, dirección y frenos del tractor funcionen apropiadamente.
- Repare un tractor que no esté funcionando apropiadamente antes de usarlo.
- Suba y baje la segadora cuando la línea de transmisión llegue al fondo o cuando existen problemas de enganche.
- Verifique que su equipo no vibre excesivamente y que no tenga ruidos anormales.
- Use prácticas apropiadas para detener el equipo antes de inspeccionarlo.

## Seguridad en el sistema de toma de fuerza y segadora

Tractores con sistemas de doble velocidad (540 ó 1000 rpm) toma de fuerza (PTO) de cambios.

### Para evitar las lesiones serias o la muerte por el fallo de piezas causado por la sobrevelocidad de la segadora:

- Asegúrese de colocar el selector de la toma de fuerza (PTO) a la velocidad de régimen de las rpm de la toma de fuerza (PTO).

### Tractores con sistemas con toma de fuerza (PTO) impulsados por la transmisión.

Una segadora rotativa tendrá un efecto significativo de volante, que puede continuar impulsando el tractor cuando tiene un sistema de toma de fuerza (PTO) impulsado por la transmisión.

### El tractor debe estar equipado y ser operado como se indica a continuación:

- Instale un embrague de sobremarcha.
- Permítase suficiente espacio y tiempo para maniobrar anticipando los virajes, paradas y reducciones de velocidad.

# Seguridad durante la operación

## Seguridad durante el enganche de la segadora al tractor

### Seguridad en el montaje de la segadora con un enganche de tres puntos:

- Haga referencia a los manuales de los fabricantes de la segadoras y el tractor.
- Coloque la palanca selectora del elevador de potencia hidráulica del tractor (eje de balancín) en posición baja para evitar el movimiento inesperado.
- Explique los procedimientos de enganche a los usuarios u operadores que no puedan leer.

### Seguridad en el montaje de la segadora con enganche de tipo tiro:

- Haga referencia a los manuales del fabricante de la segadora y tractor.
- Utilice solamente un enganche de barra de tiro.
- No la enganche al eje trasero del tractor ni a los brazos del enganche de tres puntos.
- Ajuste la longitud de la barra de tiro del tractor para la operación de la toma de fuerza (PTO) de 540 ó 1000 rpm.

## Comience el uso de la segadora en forma correcta para mayor seguridad

Segue solamente durante el día o cuando exista iluminación artificial adecuada.

### Para evitar las lesiones serias o la muerte causadas por objetos despedidos por la segadora o contacto con las hojas:

- Mantenga los blindajes de la cadena, blindajes deflectores flexibles o sólidos, conductos de descarga, colocados en su lugar y en buen estado.
- Mantenga a todas las personas a varios cientos de pies (300 [100 m]) de la operación de segado.
- Nunca dirija hacia ninguna persona la descarga de la segadora.
- Mantenga las manos, pies y otras partes del cuerpo alejadas de las piezas rotativas, hojas y agujeros de descarga.
- No debe operar la segadora en posición de transporte.

### Enganche de la transmisión, toma de fuerza (PTO) de la segadora:

- Suba la segadora a la altura máxima de corte.
- Enganche la toma de fuerza (PTO) con rpm bajas del motor.
- Aumente las rpm del motor a la velocidad de régimen de las rpm de la toma de fuerza (PTO).
- Baje la segadora a la altura de corte deseado.
- Deténgase y pare inmediatamente si la segadora golpea una obstrucción.
- Inspeccione y repare cualquier daño que tenga la segadora antes de reiniciar el segado.
- No debe operar la segadora cuando tenga vibración excesiva o ruidos anormales.

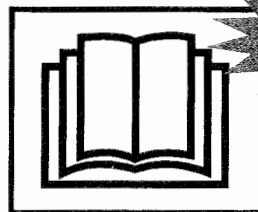

LEA  
los manuales

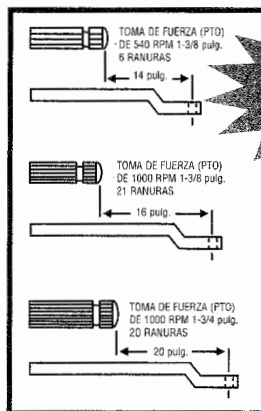

Ajuste  
de la barra  
de tiro del  
TRACTOR

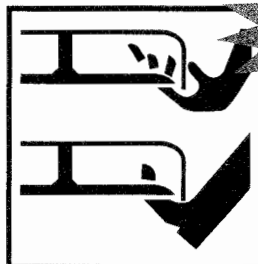

Mantenga la  
distancia de  
LAS HOJAS  
ROTATIVAS

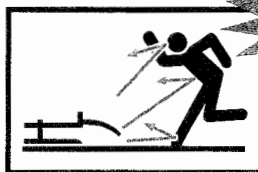

MANTENGA  
alejados a los  
transeúntes

**CUIDE**  
que no haya  
más personas

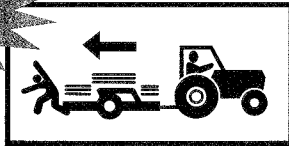

**MANTENGA**  
el rodillo  
trásero de la  
desgranadora

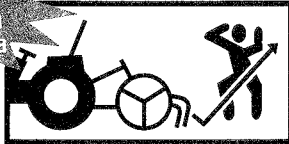

**USE** las  
velocidades  
absolutas  
apropiadas

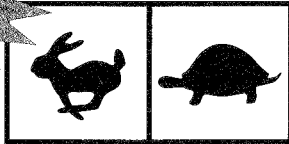

**DETENGA**  
LA HOJA  
antes de eliminar  
obstrucciones



**ESTABLEZCA**  
QUE el espacio  
libre sea adecuado  
para la oscilación  
de la segadora

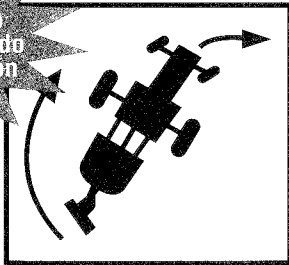

**NUNCA**  
PERMANEZCA  
DE PIE sobre  
la defensa de  
la segadora

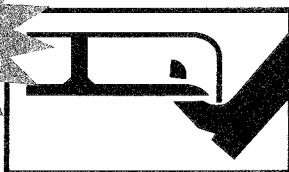

**MANTENGA**  
EL CONDUCTO  
colocado en  
su lugar

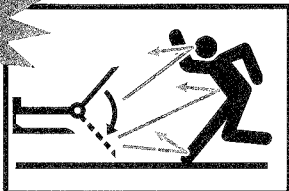

## **Seguridad durante el segado en marcha atrás**

Evite segar en marcha atrás siempre que sea posible.

Haga lo siguiente cuando segue en marcha atrás:

- Verifique que no haya personas atrás de la segadora antes de dar marcha atrás.
- Use extremo cuidado al invertir la dirección del segado.
- Mantenga los blindajes de seguridad delanteros y traseros y los blindajes delanteros de la desgranadora y los rodillos traseros de la segadora rotativa.

## **Velocidad absoluta de segado**

La velocidad absoluta depende de las condiciones del terreno, tipo de pasto, densidad y la altura de corte:

- El alcance normal de la velocidad absoluta es de 2 a 5 mph.
- La velocidad absoluta debe ser menor cuando segue pasto alto y denso.
- La velocidad absoluta puede ser mayor cuando segue pasto de altura mediana, delgado y cuando las condiciones del terreno sean uniformes.
- Use una velocidad absoluta menor cuando segue en pendientes accidentadas o terreno desconocido.

**Segado de pasto extremadamente alto**

- Puede ser necesario segar dos veces el pasto extremadamente alto.

**Primera pasada de segado:**

- Haga un corte alto al pasto (10-15 pulgadas [25-38 mm]) para evitar objetos escondidos.

**Segunda pasada de segado:**

- Retire los desechos y otros objetos.
- Corte el pasto a la altura deseada y a 90 grados de la primera pasada siempre que sea posible.
- Use las prácticas apropiadas de parada del equipo para su seguridad al bajar del tractor.

**Vigile los espacios libres del equipo**

Las segadoras con enganche de tres puntos y de montaje lateral tienen un arco de viraje mayor que las segadoras de tiro. Permita suficiente espacio libre para virar con seguridad.

## **Seguridad en el uso de las segadoras montadas en la parte inferior**

Cuando segue con una segadora montada en la parte inferior:

- Mantenga el conducto de descarga desmontable colocado en su lugar sobre el agujero de descarga.
- Nunca permanezca de pie sobre la cubierta de una segadora que esté en operación.
- Distribuya el pasto cortado con el conducto de descarga hacia el área ya segada.
- Use las prácticas apropiadas para la parada del equipo antes de eliminar las obstrucciones de la segadora o conducto de descarga.

## **Riesgos y peligros de obstrucciones elevadas cuando se usan segadoras de ala o pescante**

Verifique que no haya obstrucciones elevadas cuando use segadoras con alas levantadas o de tipo pescante, para evitar lesiones graves o la muerte causadas por el contacto con:

- Líneas de transmisión de energía eléctrica.
- Ramas bajas de árboles.
- Otras obstrucciones elevadas.

## **Seguridad en el uso de las segadoras de ala y de montaje lateral**

**Cuando utilice segadoras de ala y de montaje lateral:**

Las posiciones con el ala levantada reducen la protección del blindaje y aumentan los riesgos de objetos despedidos y de contacto con la hoja.

**Para evitar las lesiones serias o la muerte causadas por objetos despedidos o contacto con la hoja por la subida y bajada de las alas durante las operaciones de segado:**

- No segue cuando haya transeúntes en el área de segado.
- Asegúrese de que no haya personas cerca cuando suba o baje las alas.
- Mantenga el período de tiempo durante el que está expuesta la hoja rotativa del ala, a un mínimo práctico durante las operaciones de segado con el ala levantada.
- Detenga el segado si entran personas en el área de segado.
- Solamente suba el ala para pasar sobre objetos que se encuentren en el camino de segado o para seguir la inclinación del terreno.
- Desenganche la transmisión del ala durante los períodos prolongados de segado con las alas levantadas.
- Después de pasar sobre un objeto o sobre inclinaciones del terreno, baje el ala levantada, al suelo.
- Permita que todas las hojas de la segadora detengan su rotación antes de levantar las secciones del ala durante otras operaciones.

## **Seguridad durante el segado de los bordes de las zanjas**

Use cuidado extremo cuando sigue los bordes de las zanjas. Vigile para ver si hay derrumbes, áreas erosionadas y obstrucciones para el segado a lo largo del borde de la zanja. El extremo delantero del tractor puede desviarse hacia la zanja al golpear las obstrucciones con las segadoras de montaje lateral o de pescante.

Las operaciones con segadoras con alas levantadas y pescantes pueden reducir la efectividad del blindaje para objetos despedidos de la segadora que sirven para proteger al operador.

**Para aumentar la protección del operador de objetos despedidos durante las operaciones en los bordes de las zanjas:**

- Use cabinas cerradas con una estructura contra vuelcos (ROPS), cubiertas protectoras especiales y otros blindajes para el operador, cuando efectúe estas operaciones.
- Inspeccione el área de segado y retire o marque todos los objetos extraños y desechos que deben evitarse con la segadora.





## Seguridad durante el segado de terreno accidentado

La estabilidad del tractor y segadora se reduce en las pendientes y terreno accidentado.

**Usted puede evitar el vuelco del tractor y segadora y mantener el control de la estabilidad del equipo haciendo lo siguiente:**

- Revisando los manuales del operador del tractor y segadora para conocer las prácticas de seguridad de operación en pendientes y terreno accidentado. Explique las prácticas a los usuarios u operadores que no puedan leer.
- Evitando operar en pendientes extremadamente inclinadas.
- Usando cuidado extremo para mantener el control sobre su equipo cuando opere en estas condiciones.
- Aumentando la estabilidad del tractor, agregando pesas a las ruedas y aumentando el espacio entre las mismas, (haga referencia al manual del operador del tractor para conocer las recomendaciones).
- Usando un tractor equipado con una estructura contra vuelcos (ROPS) y cinturón de seguridad para la seguridad del operador durante las operaciones de segado.
- Manteniendo una velocidad absoluta mínima.
- Haciendo virajes anchos y graduales.
- Evitando arranques, paradas y virajes repentinos cuando opere subiendo, bajando o atravesando las pendientes.
- No subiendo del suelo las segadoras montadas atrás o lateralmente ni las alas de segado durante estas operaciones.
- Manteniéndose alerta por si hubiera agujeros, baches, surcos, piedras, troncos u otras obstrucciones que podrían volcar el tractor y segadora.
- Evitando las condiciones de suelo resbaloso que podrían volcar el tractor y segadora.
- Evitando que el tractor y segadora queden atascados al pasar diagonalmente sobre declives y bajadas escarpadas pronunciadas.

**Use extremo cuidado para mantener la estabilidad del equipo durante todas las operaciones sobre terreno accidentado y pendientes. Usted tiene la palabra final referente a cualquier pendiente que pueda ser trabajada en forma segura.**

## Seguridad durante el transporte del equipo en caminos

**Si es necesario conducir el equipo sobre los caminos públicos:**

- Haga referencia al manual del operador del fabricante del tractor y segadora para conocer las instrucciones.
- Explique las instrucciones a los usuarios u operadores que no puedan leer.
- Verifique las reglamentaciones locales referentes a las marcas, luces, luces intermitentes, etc., requeridas del equipo para el desplazamiento sobre caminos públicos. Se requiere de luces para las segadoras que obstruyen las luces traseras del tractor y/o las luces de advertencia.

**Antes del transporte en caminos públicos:**

- Desenganche la toma de fuerza (PTO) conectada a la segadora.
- Suba la segadora a la posición de transporte.
- Asegure las alas en la posición de transporte con los seguros en las segadoras de tipo ala y de montaje lateral.
- Enganche la cadena de seguridad entre la segadora de tipo tiro y el tractor.
- Asegúrese de que las luces, luces intermitentes, reflectores y avisos de vehículo de movimiento lento (SMV) están colocados y visibles.
- Revise que el emblema de vehículo de movimiento lento (SMV) sea visible para cualquier vehículo que se acerque desde atrás.

### Cuando transporte en caminos públicos:

- Obedezca todas las reglamentaciones locales de tráfico.
- Acérquese a las intersecciones con precaución.
- Cumpla con los avisos de velocidad y de control de tráfico.
- Evite las paradas bruscas y doblar repentinamente.

### Seguridad durante el estacionamiento

#### Estacione el equipo en:

- Áreas designadas o alejadas del tráfico.
- Preferentemente utilice lugares en terreno nivelado.

#### Lugares de estacionamiento en terreno inclinado:

- Coloque el equipo en posición transversal en las pendientes.
- Aplique los frenos de estacionamiento.
- Baje la segadora al suelo.
- Coloque bloques en las ruedas del tractor.

#### Antes de estacionar temporalmente y abandonar el equipo incapacitado cerca de áreas con tráfico:

- Retire el equipo de los caminos públicos.
- Coloque las banderas de advertencia.
- Use las luces intermitentes del tractor.

## Seguridad durante la parada

### Para su seguridad use las prácticas apropiadas para la parada del equipo

Haga referencia al (los) manual(es) del operador del fabricante del tractor y segadora para conocer los procedimientos de parada recomendados. Explique los procedimientos a los usuarios u operadores que no puedan leer.

#### Haga que los procedimientos apropiados de parada del equipo sean una costumbre importante que se debe practicar. Siga estas prácticas de seguridad antes de bajarse del tractor:

- Desenganche el embrague y transmisión de la toma de fuerza (PTO).
- Para que el motor enfríe gradualmente permita que funcione al ralentí.
- Coloque los controles en estacionamiento (P) o en punto muerto (N).
- Coloque el freno de estacionamiento.
- Baje la segadora al suelo.
- Baje al suelo las alas de las segadoras de tipo ala.
- Apague el motor.
- Espere a que todas las piezas movibles se detengan antes de efectuar inspecciones, ajustes o reparaciones al equipo.
- Descargue la presión hidráulica moviendo los controles hidráulicos varias veces en todas las direcciones.
- Asegure la ignición y extraiga la llave cuando el equipo debe ser inspeccionado, reparado, ajustado o va a permanecer desatendido.
- Asegure las cubiertas contra el vandalismo cuando el equipo permanece desatendido.
- Baje cuidadosamente manteniendo un contacto de tres puntos.

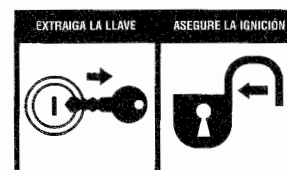
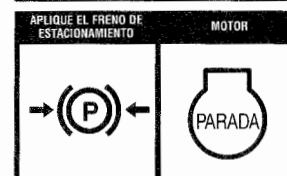
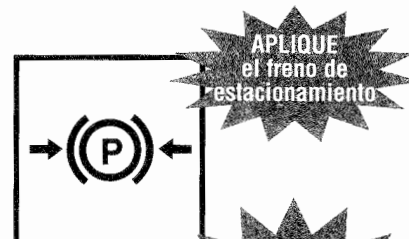

**ESPERE** que las piezas móviles se detengan antes de bajar

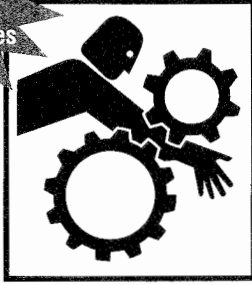

**USE** el contacto de tres puntos



**DE** MANTENIMIENTO a su equipo

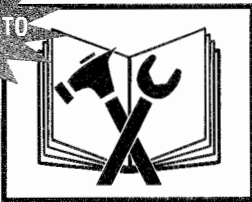

**CUMPLA**

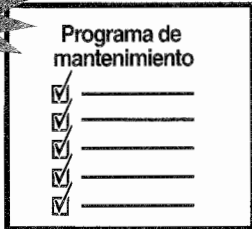

## **Seguridad durante la bajada del tractor**

**Antes de bajar del tractor haga lo siguiente:**

- Para su seguridad, use las prácticas apropiadas para la parada del equipo.
- Baje el implemento al suelo, apague el motor y la toma de fuerza (PTO), aplique los frenos, permita que se detengan todas las piezas móviles y extraiga la llave antes de bajar del tractor.
- Nunca baje del equipo cuando esté en movimiento.
- Nunca salte de las máquinas.
- Baje cuidadosamente.
- Verifique que los escalones no estén resbalosos.
- Mantenga los pies y manos alejados de los controles.
- Use las asas para las manos y los escalones para bajar.
- Vea hacia la máquina y use el contacto de 3 puntos (2 manos, 1 pie ó 2 pies, 1 mano).

## **Seguridad durante el mantenimiento**

### **Seguridad durante el mantenimiento**

**Para su seguridad haga lo siguiente antes de efectuar procedimientos de mantenimiento, reparación o servicio:**

- Cumpla con la práctica apropiada para la parada del equipo.
- Use toda la ropa protectora y equipo de seguridad personal necesarios para efectuar el trabajo en forma segura.
- Haga referencia a sus manuales del fabricante para conocer los procedimientos correctos de mantenimiento, reparación y servicio. Explique los procedimientos a los usuarios y operadores que no puedan leer.

Las fuentes de energía almacenada (eléctrica, mecánica, hidráulica, neumática, química, térmica etc.) deben estar aseguradas, bloqueadas, descargadas, desconectadas, apagadas, aseguradas, neutralizadas, controladas o reducidas a un mínimo práctico, antes de efectuar con seguridad cualquier procedimiento de mantenimiento, reparación o servicio.

**Algunas prácticas de seguridad básicas para evitar posibles lesiones causadas por las fuentes que emiten energía:**

- Desenganche la toma de fuerza (PTO) antes de apagar el motor.
- Coloque los controles en estacionamiento (P) o punto muerto (N) antes de apagar el motor.
- Aplique el freno de estacionamiento o coloque bloques en las ruedas.
- Permita que todas las piezas movibles se detengan.
- Baje la segadora al suelo.
- En las segadoras de tipo ala, baje las alas al suelo.
- Apague el motor del tractor.
- Asegure la ignición y extraiga la llave.
- Observe y escuche para establecer si hay piezas en movimiento antes de abrir los blindajes.
- Soporte o coloque bloques firmemente debajo de la segadora antes de trabajar debajo de la segadora u otros componentes elevados.
- Soporte, coloque bloques o asegure firmemente las alas de la segadora con los seguros antes de trabajar cerca o debajo de una segadora de tipo ala.
- Descargue la presión del sistema hidráulico moviendo los controles varias veces en todas direcciones.
- Descargue la presión antes de desconectar o desensamblar cualquier sistema presurizado.
- Coloque bloques o descargue la presión del resorte antes de desensamblar cualquier dispositivo a resorte.
- Soporte o bloquee firmemente cualquier componente de la máquina que esté elevado, antes de trabajar en ella.
- Evite las llamas, chispas o fumar cerca de cualquier combustible.



**Su seguridad y las piezas del fabricante para la segadora**

La mayoría de los fabricantes de segadoras usan sujetadores y piezas especialmente diseñadas para cumplir con los requerimientos de la operación de segado.

Seguridad crítica – piezas relacionadas (pernos de la hoja autoasegurados, hojas, pasadores, blindajes u otros artículos especiales) tienen requerimientos de fuerza, diseño y encaje específicos para el estilo y modelo de la segadora que usted utiliza.

Las modificaciones o piezas para reparación que no son aprobadas por el fabricante de la segadora pueden causar un riesgo significativo por exposición a su seguridad y la de los demás.

**PARA EVITAR LAS LESIONES SERIAS O LA MUERTE CAUSADAS POR PIEZAS O MODIFICACIONES NO APROBADAS:**

- No sustituya accesorios comunes por los pernos autoasegurados de las hojas u otras piezas especiales.
- No sustituya las hojas, pasadores, blindajes u otras piezas relacionadas con la seguridad crítica.
- No use pernos de grado 5 u 8 para reemplazar los pernos de resistencia limitada grado 2.

**CUMPLA LA PRÁCTICA SEGURA DE SIEMPRE VERIFICAR EL FUNCIONAMIENTO CORRECTO DE TODOS LOS AJUSTES, REPARACIONES O SERVICIO DE LA SEGADORA.**

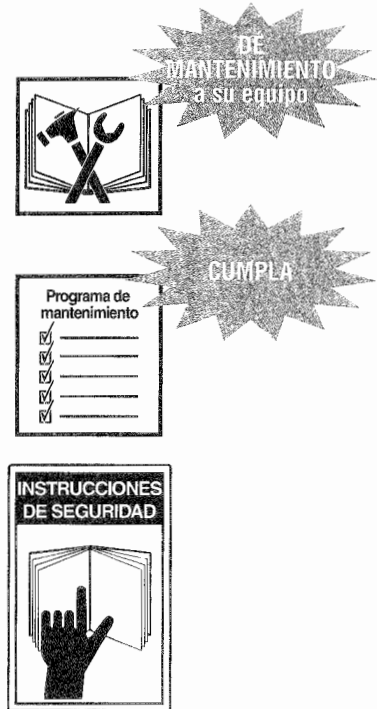



## **Palabra final**

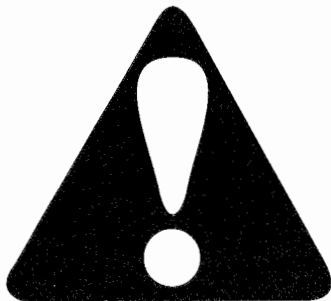

Usted ha terminado de leer el manual de seguridad de la segadora. Es imposible que este manual incluya toda situación peligrosa potencial que usted pueda encontrar. Sin embargo, su conocimiento de estas precauciones de seguridad y su cumplimiento de las reglas básicas de seguridad le ayudarán a crear buen juicio para todas las situaciones. Nuestro objetivo es ayudarle a desarrollar buenos hábitos de seguridad y hacerlo un mejor operador de segadora. El manual de seguridad de la segadora, precauciones de seguridad y reglas básicas de seguridad deben explicarse a los usuarios u operadores que no puedan leer.

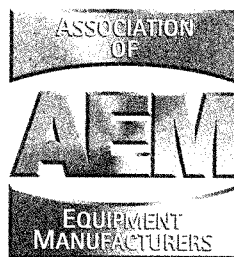

111 E. Wisconsin Avenue • Milwaukee, Wisconsin 53202 U.S.A.  
[www.aem.org](http://www.aem.org)

Para obtener información de reproducciones adicionales y  
otros manuales de seguridad, llame al 800-369-2310

# **INTRODUCTION SECTION**

Introduction Section 2-1

# INTRODUCTION

This Rotary Mower is designed with care and built with quality materials by skilled workers. Proper assembly, maintenance, and operating practices, as described in this manual, will help the owner/operator get years of satisfactory service from the machine.

The purpose of this manual is to familiarize, instruct, and train. The Assembly Section instructs the owner/operator in the correct assembly of the Mower using standard and optional equipment. The Parts Listing section is designed to familiarize the owner/operator with replaceable parts on the Mower. This section provides exploded assembly drawings of each mower component illustrating each piece and the corresponding part number.

Careful use and timely service save extensive repairs and costly downtime losses. The Operation and Maintenance Sections of the manual train the owner/operator how to work the Mower correctly and attend to appropriate maintenance. The Trouble Shooting Guide helps diagnose difficulties with mower and offers solution to the problems.

Safety is of primary importance to the owner/operator and to the manufacturer. The first section of this manual includes a list of Safety Messages, that, if followed, will help protect the operator and bystanders from injury or death. Many of the Safety Messages will be repeated throughout the manual. The owner/operator/dealer should know these Safety Messages before assembly and be aware of the hazards of operating this blade during assembly, use, and maintenance. The Safety Alert Symbol combined with a Signal Word, as seen below, is intended to warn the owner/operator of impending hazards and the degree of possible injury faced when operating this machine.



Indicates an imminently hazardous situation that, if not avoided, WILL result in DEATH OR VERY SERIOUS INJURY.



Indicates an imminently hazardous situation that, if not avoided, COULD result in DEATH OR SERIOUS INJURY.



Indicates an imminently hazardous situation that, if not avoided, MAY result in MINOR INJURY.

**Important**

Identifies special instructions or procedures that, if not strictly observed, could result in damage to, or destruction of the machine, attachments or the environment.

# INTRODUCTION

## Pull-Type Model

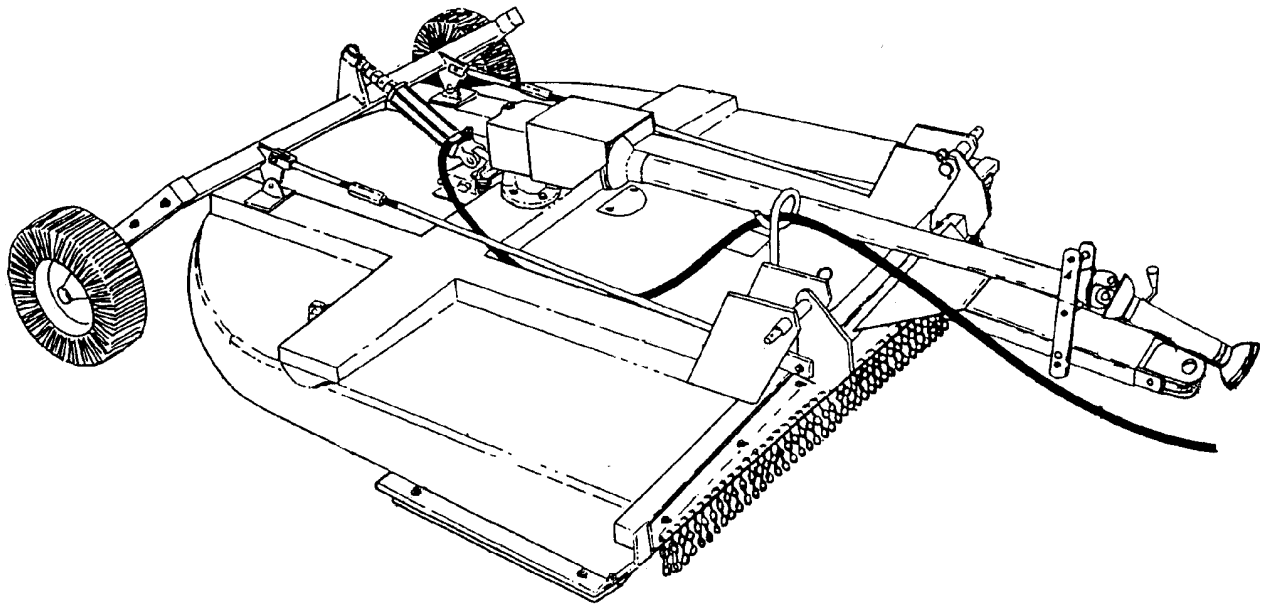

FC-0002

These mowers are available in lift-type and pull-type. These rugged Mowers are designed for medium-duty work. They can mow pastures, cut brush up to 4" in diameter, and control grass and weeds on highways or industrial sites.

**▲ DANGER**

For Non-Agricultural use, OSHA, ASAE, SAE, and ANSI standards require the use of Chain Guards or Solid Skirts at all times. The Cutter manufacturer strongly recommends the use of Chain Guards or Solid Skirts for Agricultural purposes as well, to reduce the risk of property damage, serious bodily injury, or even death from objects thrown out by or from contact with the Cutting Blades.

The 84" Lift-Type machine requires a minimum of 60 HP with adequate front end weight.

**▲ WARNING**

At least 20% of the tractor's weight must be on the front tires with the implement lifted to provide adequate traction for safe steering under good conditions. Slow down on hills, rough terrain, and curves.

Front and rear, and left and right are determined by the normal direction of travel (the same as on your automobile).

# INTRODUCTION

## Attention Owner/Operator

BEFORE OPERATING THIS MACHINE:

1. Carefully read the Operator's Manual, completely understand the Safety Messages and instructions, and know how to operate correctly both the tractor and implement.
2. Fill out the Warranty Card in full. Be sure to answer all questions, including the Serial Number of the implement. Mail within 30 days of delivery date of this implement.

**NOTE:** Warranties are honored only if completed "Owner Registration and Warranty" forms are received by Alamo Group within thirty days of delivery of the implement.

3. Record the Blade Model and Serial Numbers on the Warranty page at the front of the Operator's Manual. Keep this as part of the permanent maintenance file for the implement.

# IMPORTANT

For your safety and to guarantee optimum product reliability, always use Genuine RHINO replacement parts. The use of inferior "will-fit" parts will void Warranty of your RHINO implement and may cause premature or catastrophic failure which can result in serious injury or death. If you have any questions concerning the repair parts you are using, contact Rhino, 1020 S. Sangamon Ave., Gibson City, Illinois 60936 A Member of Alamo Group



# **ASSEMBLY SECTION**

Assembly Section 3-1

# ASSEMBLY

## Optional A-Frame Assembly

(Figure Asm-0032)

To assemble the Mower's A-Frame, follow the procedures listed below:

1. Insert bushing (5) into lower end of each A-Frame half (1 & 2). Position each A-Frame half so the large hole in the top is towards the tractor. Install 3/4 x 2" bolt (10) with Flatwasher (14) through bushing (5) in A-Frame half (1 & 2) and rear hole in inside Main Frame lug. Install locknut.
2. Install bushing (8) between braces (3) through top rear hole of A-frame and insert bolt (12), flatwasher (14) and locknut (13).
3. Install bushing (22) between A-Frame halves (1 & 2) and insert bolt (23) and locknut (13). Install bushings (6) through Braces (4) and install bolt 3/4 x 5 (10), flatwashers (14) and locknut (13).
4. Attach Braces (3) to Braces (4) with bushings (6), bolt 3/4 x 2-1/2 (16), and locknut (13). Retain the rear of Braces (3) together with bushing (15), bolt 3/4 x 2-1/2 (11) and locknut (13). Attach braces (4) together with bolt 3/4 x 1-1/2 (17) and locknut (13).
5. Install Brace supports (4) to the rear lugs on the Main Frame with bolts 3/4 x 2 (10), flatwashers (14), bushings (6) and locknuts (13).

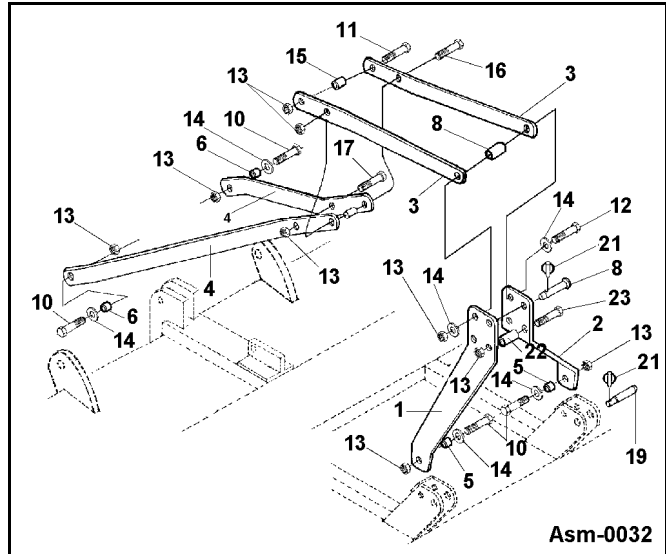

## Single Tail Wheel Assembly - Lift-Type

(Figure Asm-0033)

Insert bushing (2) in lug centered behind gearbox. Attach the tail wheel beam (1) to the lug on the mower deck using bolt (3) and locknut (4).

Attach the brackets (5 & 6) to the main deck using bolts (8), washer (9), & nuts (10). Note: Formed leg with adjustment holes must point to rear and should be on each side of tail wheel beam.

Install bolts (11) & nuts (12) on top and bottom of tail wheel beam. Insert through pair of holes which will give approximate desired cutting height. Tighten all bolts per Torque Chart.

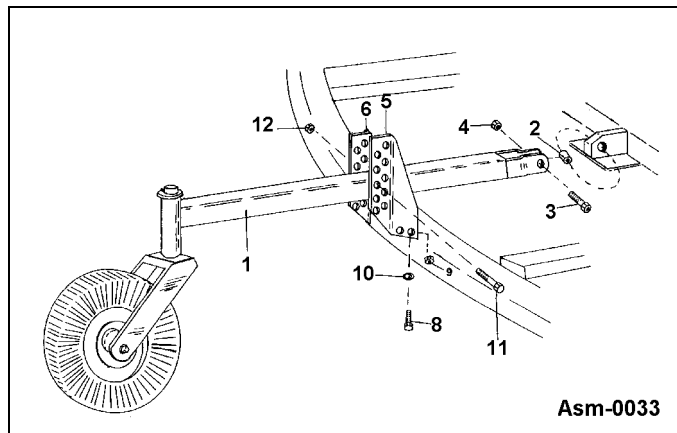



# ASSEMBLY

## Dual Tail Wheel Assembly

### Lift-Type (Figure Asm-0034)

Attach the tail wheel beam (1) to the lug toward the outer edge of the deck just to the rear of the cross reinforcement using bolt (2) & nut (3).

Attach the brackets (5 & 6) to the deck using bolts (7), washers (8), and nuts (9).

**NOTE:** Formed leg with adjustment holes point to rear on part (5) and to front on part (6).

Install bolts (10) & nuts (11) on top and bottom of tail wheel beam. Insert through pair of holes which will give approximate desired cutting height. Tighten all bolts.

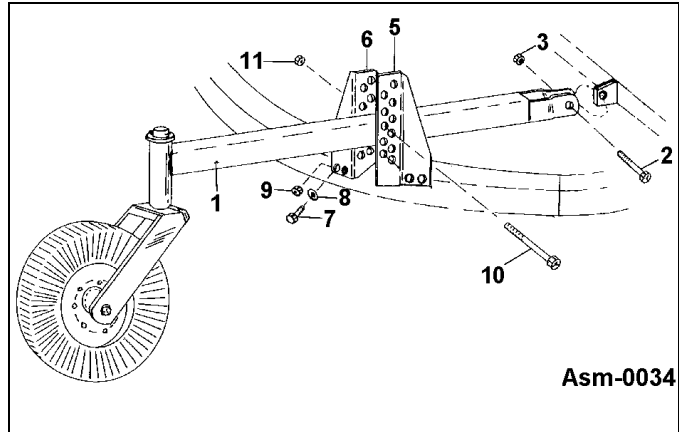

### Pull-Type

The standard Pull-Type unit will be shipped from the factory in the following bundles: 1) Basic Assembly, 2) Jackshaft Assembly, 3) Jackshaft Bearing Support, 4) Gearbox Protective Shield, 5) PTO Driveline, 6) Tongue Assembly, 7) Control Rod Bundle, 8) Axle Arm Bundle and Lift Lug and/or Spring Assembly, 9) Wheels, 10) Jack, 11) Operator's Manual and Flat Blades. Other optional bundles that may be shipped with your unit: Ratchet Lift Screw or Hydraulic Cylinder with Hydraulic Hose and Hose Bracket, Puncture-Proof tires or 14" or 15" Wheels, Chain Guards. Extra Equipment items include: Chain Guards, Solid Guards, Dual Wheels, Hitch and Spring Assembly (Axle).

### CAUTION

The Components of these machines are quite heavy. Block all components up securely before working under or putting extremities under such parts.

## Tongue

Insert tongue lugs between mainframe uprights and retain using special pin. Insert retaining clip to retaining pin (Figure Asm-0035).

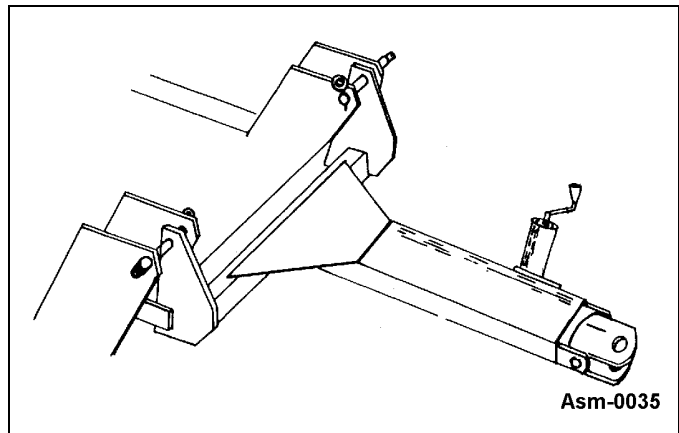

# ASSEMBLY

## Axle

Attach Rear Axle to the lugs on the rear of the mainframe using (5) 3/4 x 3-1/2 bolts and locknuts (**Figure Asm-0036**).

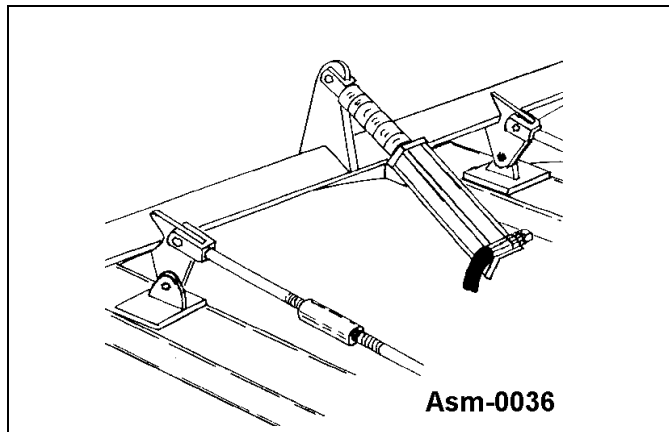

## Control Rods

Attach the two level-lift control rods to the lower lugs on tongue and to lugs on the rear axle tube using pins, washers and cotter pins.

**NOTE:** The adjusting nuts on control rods should be to rear of machine (**Figure Asm-0037**).

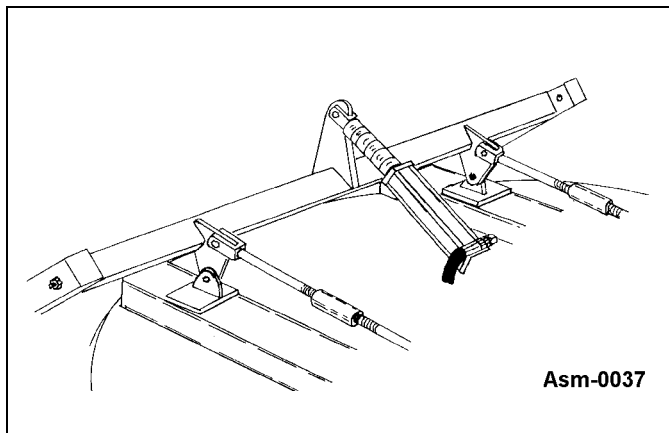

# ASSEMBLY

## Hydraulic or Manual Lift

Attach the Spring Assembly (**Figure Asm-0038**) to the lug on the mower deck behind the Center Gearbox. Retain using 3/4 x 3 capscrews and locknuts. Install the Hydraulic Cylinder or the manual Ratchet Lift Screw (**Figure Asm-0039**) between the Axle Center Lug and the Lug directly behind the Center Gearbox. Tighten the two Bolts securely.

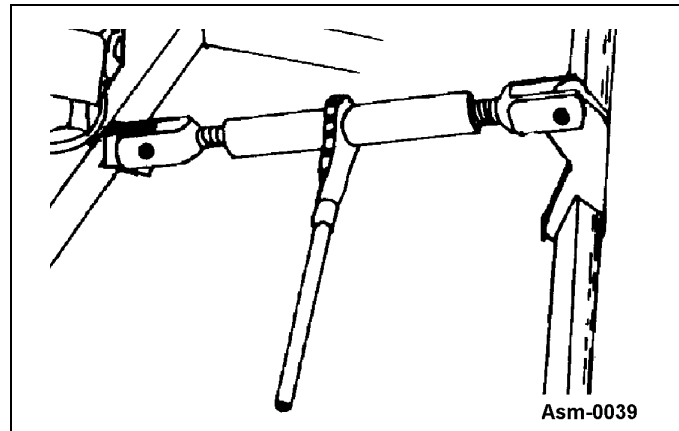
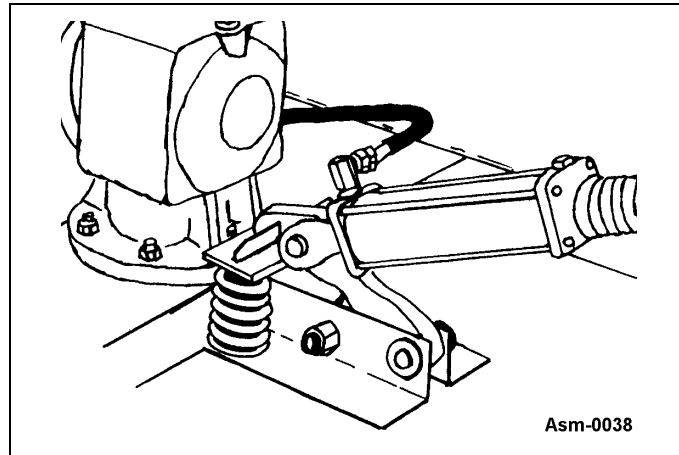

## Wheels

Install the Wheels on the Wheel Hubs. **NOTE: If Laminated Tires are used, place the flat side of the Lug Nut against the Wheel (Figure Op-42).** Note direction of travel and curvature of rubber segments in tire and install as shown in (**Figure Op-42**).

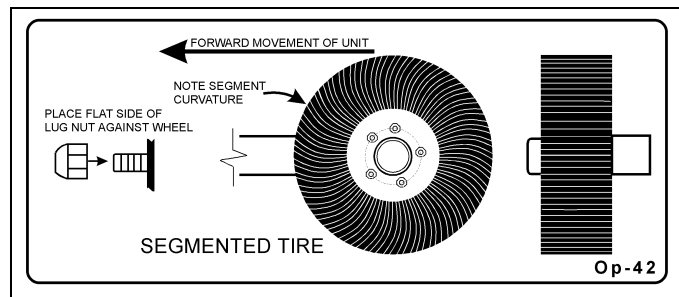

# ASSEMBLY

## Shields, Guards, and Deflectors

Shields, Guards, and Deflectors are provided for the protection of the operator and bystanders. The Manufacturer strongly recommends the use of Protective Shielding at all times. Do not operate the machine without Shields in place.

Make certain that all Driveline Shields are installed and turn freely and that the tractor PTO shield is replaced before starting the PTO. Attach the other chains on shields to mower and to tractor to prevent shield rotation.

### Rubber Fabric Deflectors (Standard Equipment)

#### Front Deflector (Figure Asm-0040)

1. Attach the front Bracket (1) to the front mower with 4 - 1/2" x 3" Bolts (5), Locknuts (6), and washers (7).
2. Attach the front Deflector to the Bracket with Strap (3), 3/8" x 1-1/2" Bolts (6), and Locknuts (4).

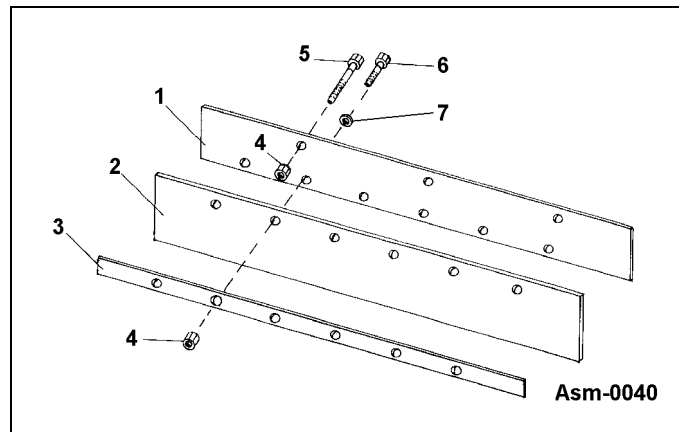

#### Rear Chain Guards (Figure Asm-0041)

Attach the Right Guard Mounting Plate (1) & the Left Chain Guard Mounting Plate (2) to the mower with 1/2" x 1-1/2" Bolts (3), Flatwashers (4) and Locknuts (5). Then attach Deflectors (6) and Bar Strap (7) to Mounting Plates with 1/2" x 1-1/2" bolts(8) Flatwashers(9) and Locknuts (10). Fasten Side Rear Chain Guard (11) to Chain Guard Mounting Plates (1&2) with 1/2" x 1-1/4" bolts (12) Flatwashers (13) and Locknuts (14).

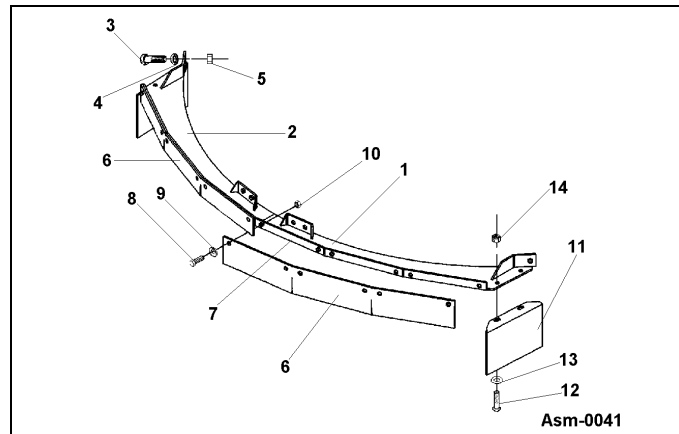

# ASSEMBLY

## Chain Guard (Extra Equipment)

### Front Chain Guards (Figure Asm-0042)

Attach the Right Chain Guard Mounting Plate (1) & the Left Chain Guard Mounting Plate (2) to the mower with 1/2" x 1-1/2" Bolts (3), Flatwashers (4) and Locknuts (5). Then attach Chain Guards (6) to Chain Guard Mounting Plates with 1/2" x 1-1/2" bolts(7) Flatwashers(8) and Locknuts (9). For Double Chain Guards attach with 1/2" x 3" bolts (10), Flatwashers (11), Spacers (12) and Locknuts (13). Fasten Side Rear Chain Guard (14) to Chain Guard Mounting Plates (1&2) with 1/2" x 1-1/4" bolts (15) Flatwashers (16) and Locknuts (17).

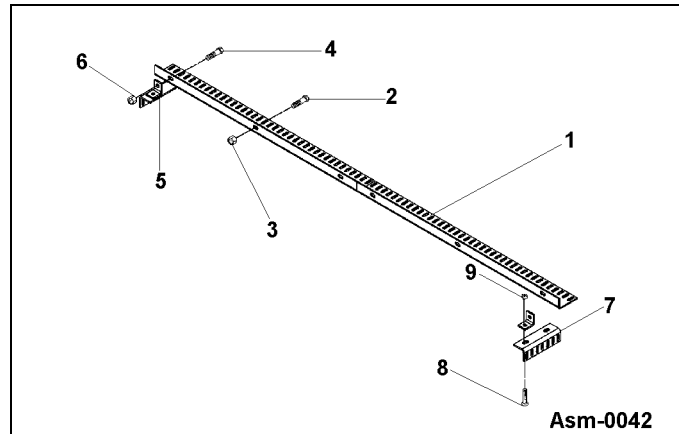

### Rear Chain Guards (Figure Asm-0043)

Attach the Right Chain Guard Mounting Plate (1) & the Left Chain Guard Mounting Plate (2) to the mower with 1/2" x 1-1/2" Bolts (3), Flatwashers (4) and Locknuts (5). Then attach Chain Guards (6) to Chain Guard Mounting Plates with 1/2" x 1-1/2" bolts (7) Flatwashers (8) and Locknuts (9). For Double Chain Guards attach with 1/2" x 3" bolts (10), Flatwashers (11), Spacers (12) and Locknuts (13). Fasten Side Rear Chain Guard (14) to Chain Guard Mounting Plates (1&2) with 1/2" x 1-1/4" bolts (15) Flatwashers (16) and Locknuts (17).

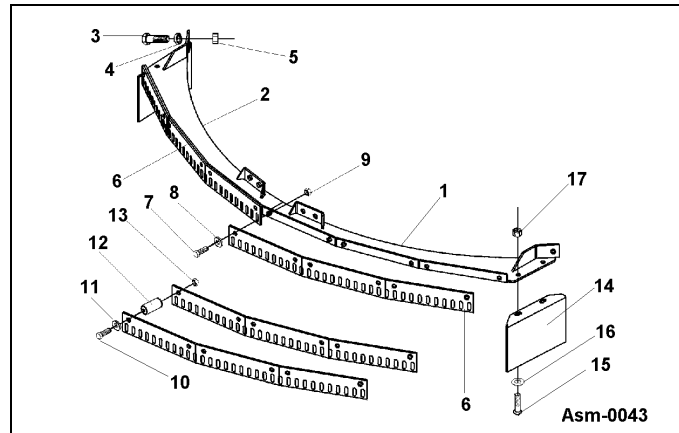

# ASSEMBLY

## Driveline Attachment

(Figure Asm-0044)

Remove washer, castle nut, and cotter pin from wing gearbox shaft. Install clutch yoke on shaft. Attach yoke to clutch by inserting spacer flat (1) between yoke and clutch. Insert 5/16 x 3-1/2 bolts (2) and install locknuts (3). Tighten securely. Install washer and castle nut on gearbox shaft between yoke ears. Tighten Mounting Nut and the back off to allow approximately .015 clearance (Figure Asm-0044).

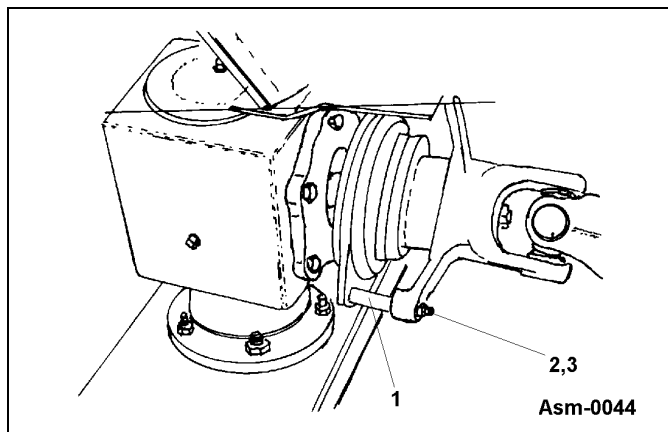

Install Canopy Shield over

Torque Limiter and make certain it remains installed at all times when operating this Mower.

## Gearbox Shield Assembly

(Figure Asm-0045)

Install the Gearbox Shield (1) using two existing bolts in gearbox top cover plate. Tighten all hardware in accordance with the torque chart in the Maintenance section of this manual. Install wing nut (2) hand-tight for ease of raising shield for service.

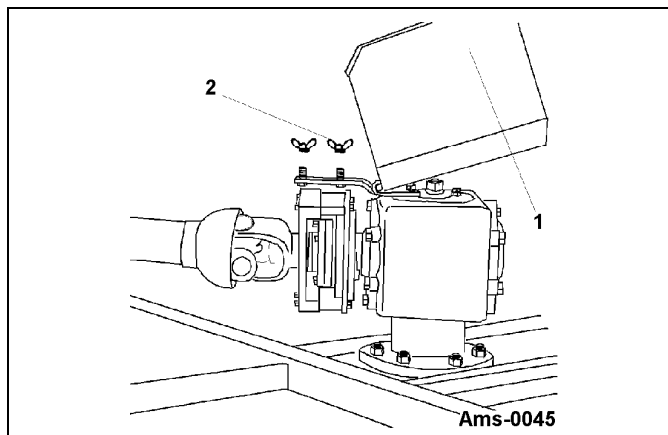

DO NOT operate if Shields are inoperative or removed.

# ASSEMBLY

## Check Chains (Extra Equipment) for Lift-Models

(Figure Asm-0046)

Check Chains are available for attachment to front of Mower as an accessory. Check chains are used to control cutting height and especially allow Mower to be lowered to the same preset cutting height effortlessly.

Install lower end of check chain (4) to hitch ears (6) through lower holes (7) using bolts, nuts and lockwashers(8). Tighten securely.

Install chain lugs (3) on either side of tractor top link mounting (5) using bolt or pin of required diameter and length. CAT I kit requires a 3/4" diameter bolt. CAT II kit requires a 1" diameter bolt. Install top end of check chains in brackets (3).

Cutting height is then set by placing proper chain link in keyhole slot. Cutting height is easily adjustable by hooking chain higher or lower in the keyholes in chain lug (3).

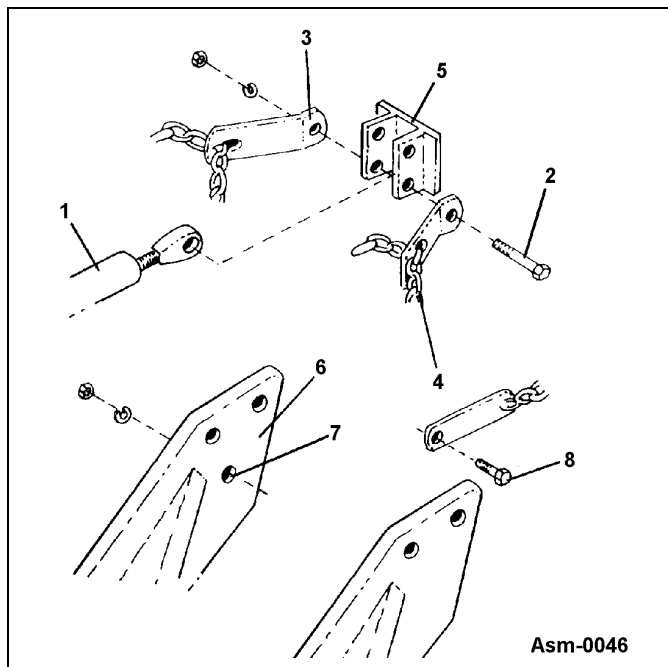

For additional safety in transport, raise mower as high as possible without having driveline hit deck and shorten check chains as much as possible to prevent inadvertent falling in transport.

**NOTE:** CHECK TO BE SURE GEARBOX IS FILLED WITH LUBRICANT TO THE TEST PLUG LEVEL. The lubricant required is SAE EP90 or SAE EP80W90 with EP additives for extreme pressure and temperature, with a API-GI-5 service rating.

ASSEMBLY

# ASSEMBLY

ASSEMBLY

## Jackshaft Bearing Support Assembly

(Figure Asm-0047)

Attach the Jackshaft bearing support brackets (1&2) to the tongue. Loosely attach bearing support brackets by using 1/2" x 7-1/2" bolt (3), washer (5), bushing (4) and nuts (6). Be sure that support brackets are assembled through rear hole on the tongue. Then assemble Snap Ring (7) Bearing (8) and housing assembly (9) and install with 3/4" x 7" bolt (10) and nut (11). Install Spacer (12) with 1/2" x 7-1/2" bolt (13) and nut (14) leaving installed loosely. Tighten bolt (13). **NOTE: Do not tighten to point of collapsing spacer (12).** Tighten bolts (3 & 10) **NOTE: Do not over tighten. Make sure Carrier Bearing (9) pivots in supports and complete assembly pivots on lower bolt.** Slide Jackshaft through bearing (9) and Snap on to the driveline (15).

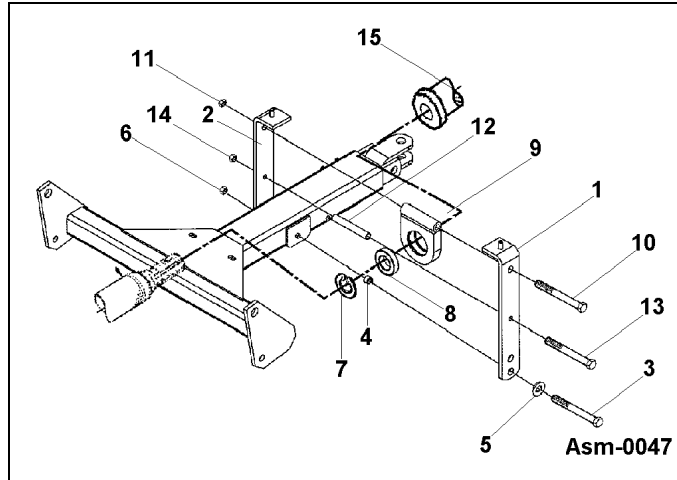

**NOTE: ALL Yokes must be set as shown for proper phasing.**

## IMPORTANT REQUIRED FOR JACKSHAFT UNIT

Adjust Bearing up or down so drive is in a straight line Gearbox to tractor PTO.

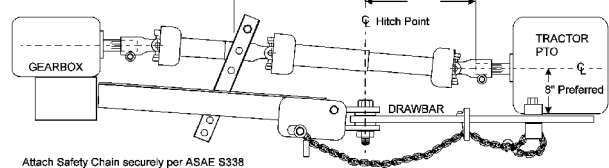

Asm-0048



# OPERATION SECTION

Operation Section 4-1

# OPERATION

## OPERATION

### RHINO CY84 HEAVY-DUTY ROTARY MOWER OPERATION INSTRUCTIONS

Rhino Cyclone 84 (CY84) Heavy-Duty Rotary Mowers are manufactured with quality material by skilled workers. These rugged mowers are engineered for cutting vegetation up to 3-1/2" diameter in commercial, industrial, and agriculture applications such as mowing rights-of-way, roadsides, and pastures. The mower is equipped with protective safety deflectors and/or chain guards to prevent objects being thrown by blades, however, no shielding is 100% effective. All shields, deflector's, and chains equipped on the unit must be maintained on the mower in good operational condition.

It is the operator's responsibility to be knowledgeable of all operating hazards and to take every reasonable precaution to ensure oneself, others, animals, and property are not injured or damaged by the mower, tractor, or a thrown object. Do Not operate the mower if passersby, pets, livestock, or property are directly in front or to the rear of the unit.

This section is designed to familiarize, instruct, and educate safe and proper mower use to the operator. Pictures contained in this section are intended to be used as a visual aid to assist in explaining the operation of a rotary mower and are not necessarily of a CY84 mower. Some pictures may show shields removed for purposes of clarity. NEVER OPERATE this implement without all shields in place and in good operational condition. The operator must be familiar with the mower and tractor operation and all associated safety practices before operating the mower and tractor. Proper operation of the CY84 mower, as detailed in this manual, will help ensure years of safe and satisfactory use of the mower.

**IMPORTANT:** To avoid damage to the cutter, retorque all bolts after the first 10 hours of operation. Retorque blade carrier retaining nut to 400 ft. lbs.

**READ AND UNDERSTAND THE ENTIRE OPERATING INSTRUCTIONS AND SAFETY SECTION OF THIS MANUAL AND THE TRACTOR MANUAL BEFORE ATTEMPTING TO USE THE TRACTOR AND IMPLEMENT.** If you do not understand any of the instructions, contact your nearest authorized dealer for a full explanation. Pay close attention to all safety signs and safety messages contained in this manual and those affixed to the implement and tractor. *OPS-U- 0001*

READ, UNDERSTAND, and FOLLOW the following Safety Messages. Serious injury or death may occur unless care is taken to follow the warnings and instructions stated in the Safety Messages. Always use good common sense to avoid hazards. (SG-2)

**SAFETY INSTRUCTIONS**



**PELIGRO**

Si no lee ingles, pida ayuda a alguien que si lo lea para que le traduzca las medidas de seguridad. (SG-3)

**¡ LEA EL INSTRUCTIVO!**



# OPERATION

## 1. Standard Equipment and Specifications

|                                 | <b>CY84</b>  |
|---------------------------------|--|
| Horsepower Required (Min.):     |  |
| Lift                            | 60 HP  |
| Pull                            | 30 HP  |
| Safety Deflector                | Rubber Belting   |
| Cutting Width                   | 84"  |
| Overall Width                   | 90-3/8"  |
| Overall Length:                 |  |
| Lift                            | 125"   |
| Pull                            | 152-1/2"   |
| Cutting Height                  | 2-3/8" - 16-1/2" Min.  |
| Self-Leveling Height Adjustment | Ratchet Jack or Hydraulic Cylinder (Pull)                                    |
| Jack Stand                      | Std. (Pull)  |
| Base Unit Weight (Approx.)      | 1869 lbs.  |
| Hitch                           | CAT II-III Q.H. or Pull  |
| Blade Carrier                   | H.D. Pan   |
| Blades                          | 1/2" x 4" Updraft  |
| Gearbox Rating:                 |  |
| 540 RPM                         | 150 HP*  |
| 1000 RPM                        | 150 HP*  |
| Output Shaft Diameter           | 2-3/8"   |
| Blade Tip Speed:                |  |
| 540 RPM                         | 16,328 FPM   |
| 1000 RPM                        | 15,994 FPM   |
| Cutting Capacity (Max.)         | 3-1/2"   |
| Driveline Size                  | Cat 5  |
| Driveline Protection            | Slip Clutch  |
| Deck Thickness                  | 3/16"  |
| Side Skirt                      | 1/4" x 10-3/4"   |
| Tires & Wheel:                  |  |
| Lift                            | Single or Dual, Laminated  |
| Pull                            | Laminated Foam-Filled Used Airplane,<br>Used Airplane,<br>Implement, 15" Rim |
| Safety Tow Chain                | Std. (Pull)  |

\*Ratings based on actual field performance.

# OPERATION

## 2. OPERATOR REQUIREMENTS

Safe operation of the unit is the responsibility of a qualified operator. A qualified operator has read and understands the implement and tractor Operator's Manuals and is experienced in implement and tractor operation and all associated safety practices. In addition to the safety messages contained in this manual, safety signs are affixed to the implement and tractor. If any part of the operation and safe use of this equipment is not completely understood, consult an authorized dealer for a complete explanation.

If the operator cannot read the manuals for themselves or does not completely understand the operation of the equipment, it is the responsibility of the supervisor to read and explain the manuals, safety practices, and operating instructions to the operator.

Safe operation of equipment requires that the operator wear approved Personal Protective Equipment (PPE) for the job conditions when attaching, operating, servicing, and repairing the equipment. PPE is designed to provide operator protection and includes the following safety wear:

### PERSONAL PROTECTIVE EQUIPMENT (PPE)

- Protective Eye Glasses, Goggles, or Face Shield
- Hard Hat
- Steel Toe Safety Footwear
- Gloves
- Hearing Protection
- Close Fitting Clothing
- Respirator or Filter Mask (depends on operating conditions) *OPS-U-0002*

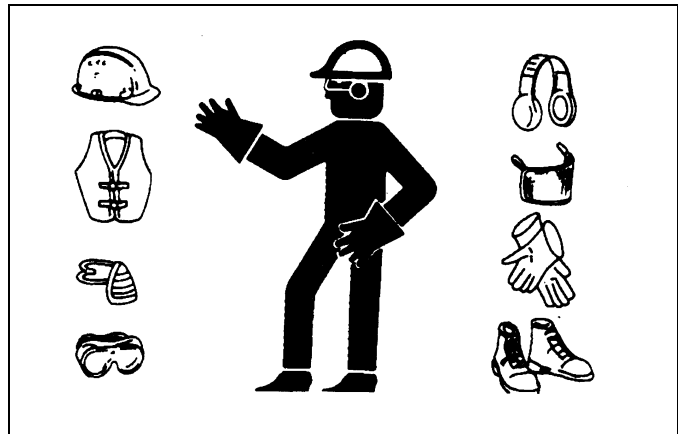

### **⚠ DANGER**

NEVER use drugs or alcohol immediately before or while operating the Tractor and Implement. Drugs and alcohol will affect an operator's alertness and coordination and therefore affect the operator's ability to operate the equipment safely. Before operating the Tractor or Implement, an operator on prescription or over-the-counter medication must consult a medical professional regarding any side effects of the medication that would hinder their ability to operate the Equipment safely. NEVER knowingly allow anyone to operate this equipment when their alertness or coordination is impaired. Serious injury or death to the operator or others could result if the operator is under the influence of drugs or alcohol. (SG-27)

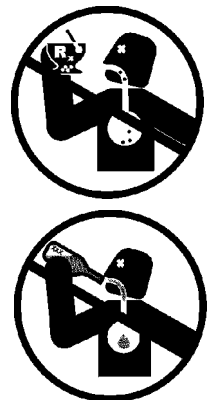

# OPERATION

## **3. TRACTOR REQUIREMENTS**

The tractor used to operate the mower must have the power capacity to lift, pull, and operate the Power Take Off (PTO) at the mower's rated speed while traveling at a ground speed between 2 and 5 MPH. Operating the mower with a tractor that does not meet the following requirements may cause tractor or mower damage and be a potential danger to the operator and passersby.

### **Tractor Requirements and Capabilities**

- ASABE approved Roll-Over Protective Structure (ROPS) or ROPS cab and seat belt.
- Tractor Safety Devices ..... Slow Moving Vehicle (SMV) emblem, lighting, PTO master shield
- Tractor Horsepower:
  - Minimum ..... Lift - 60 HP, Pull - 30 HP
  - Maximum ..... 90 HP
- Hitch - Lift-Type Mower
  - Lifting Capacity ..... 1600 lbs.
  - 3-Point Hitch ..... CAT II-III Quick Hitch
- Hitch - Pull-Type Mower
  - Drawbar ..... 14" extended length, safety chain attachment point
  - Hydraulics ..... Optional
- Front End Weights ..... As needed to maintain 20% weight on front axle
- Power Take Off ..... 540 RPM 6-spline or 1000 RPM 21-spline shaft

### **3.1 ROPS and Seat Belt**

The tractor must be equipped with a Roll-Over-Protective-Structure (ROPS) (tractor cab or roll-bar) and seat belt to protect the operator from falling off the tractor, especially during a roll over where the driver could be crushed and killed. Only operate the tractor with the ROPS in the raised position and seat belt fastened. Tractor model not equipped with a ROPS and seat belt should have these life saving features installed by an authorized dealer. *OPS-U- 0003*



Operate this Equipment only with a Tractor equipped with an approved roll-over-protective system (ROPS). Always wear seat belts. Serious injury or even death could result from falling off the tractor--particularly during a turnover when the operator could be pinned under the ROPS. (SG-7)



### **3.2 Tractor Safety Devices**

If transporting or operating the tractor and implement near a public roadway, the tractor must be equipped with proper warning lighting and a Slow Moving Vehicle (SMV) emblem which are clearly visible from the rear of the unit. Lights and a SMV emblem must be equipped directly on implements if the visibility of the tractor warning signals are obscured.

Maintain all manufacturer equipped safety shields and guards. Always replace shields and guards that were removed for access to connect, service, or repair the tractor or implement. Never operate the tractor PTO with the PTO master shield missing or in the raised position. *OPS-U- 0004*

# OPERATION

### 3.3 Tractor Horsepower

The power required to operate a mower is determined by the tractor PTO horsepower. For most mowing conditions, the CY84 mower requires a tractor with at least 60 HP for a lift unit and 30 HP for a pull-type. Operating the mower with a tractor that does not have adequate power may damage the tractor engine. Exceeding 90 HP may cause mower damage by overpowering the unit in heavy cutting conditions.

### 3.4 3-Point Hitch

The tractor 3-point hitch must be rated to lift at least 1600 lbs.

The CY84 mower is designed to be mounted on a tractor with a CAT II or III 3-point hitch. Refer to the tractor operator's manual for the category of the tractor being used. If the hitch does not conform to ASAE CAT II or III dimensions, the mower may not fit or raise properly. Consult an authorized dealer for possible modification procedures to mount nonconforming hitches.

Depending on the hitch category, certain size pins are used to attach the mower to the tractor. CAT II hitches require 7/8" lower and 3/4" upper diameter hitch pins. CAT III hitches require 1-7/16" lower and 1-1/4" upper diameter size pins.

#### CAT II Implement / Hitch Specification

|   |         |
|---|---------|
| Width from outside to outside A-frame.....    | 32-3/8" |
| Quick Hitch width inside lug to lug .....     | 33-5/8" |
| Height from bottom hitch pin to top pin ..... | 19"     |
| Lower pin diameter .....                      | 1-1/18" |
| Upper pin diameter .....                      | 1"      |
| Lynch pin diameter .....                      | 15/32"  |

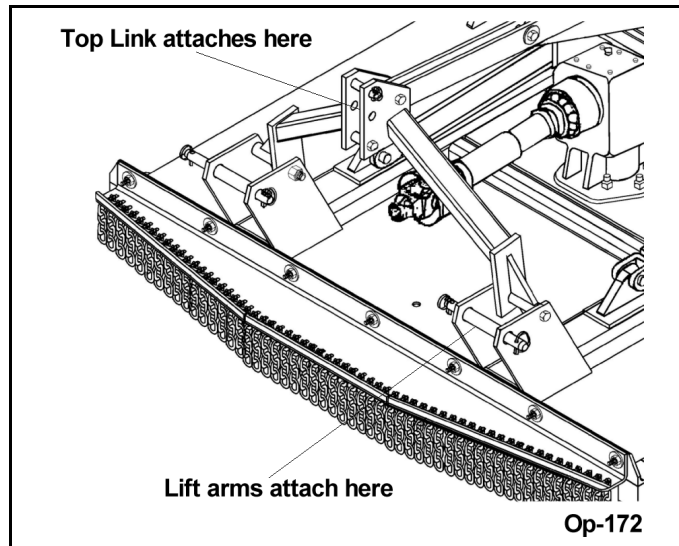

|   |         |
|---|---------|
| Width from outside to outside A-frame .....   | 38"     |
| Quick Hitch width inside lug to lug .....     | 39-1/4" |
| Height from bottom hitch pin to top pin ..... | 22"     |
| Lower pin diameter .....                      | 1-7/16" |
| Upper pin diameter .....                      | 1-1/4"  |
| Lynch pin diameter .....                      | 15/32"  |

# OPERATION

## **3.5 Drawbar - Pull-Type Mower**

For pull-type mowers (540 and 1000 RPM) equipped with an equal-angle driveline, the tractor drawbar must be positioned at a 14" distance from the hitch point to the PTO shaft end for proper operation and minimal wear to the driveline and tractor.

If attaching the mower tongue clevis to a 3-point hitch drawbar supported by the lower lift arms, the attaching point must be extended past the main bar to allow for turning without binding the clevis and bar. Lift arm stabilizers must be used with this type of drawbar to prevent the mower from swaying from side to side.

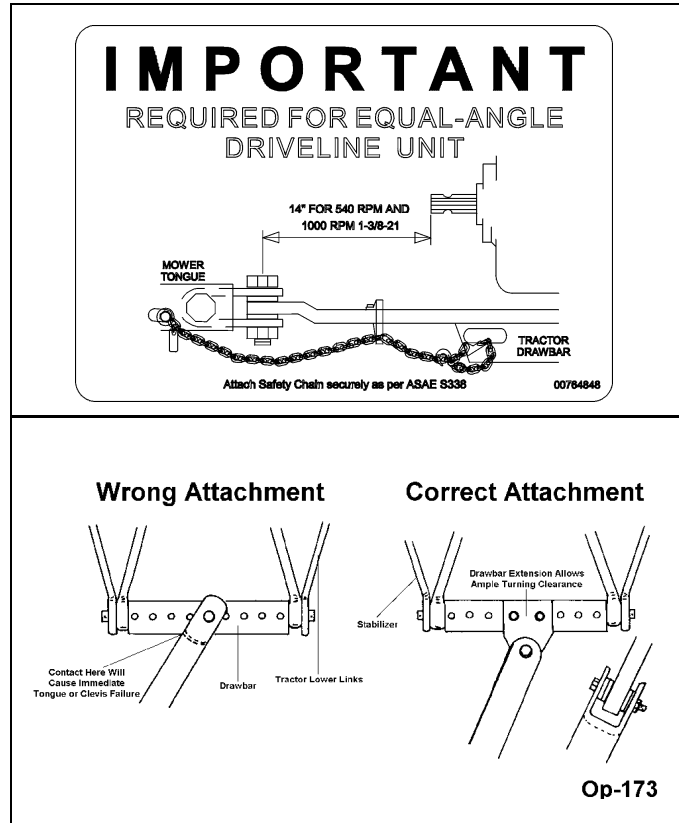

## **3.6 Front End Weight**

A minimum of 20% total tractor weight must be maintained on the tractor front end at all times. Front end weight is critical to maintain steering control and to prevent the tractor from rearing up while driving. If the front end is too light, add weight until a minimum of 20% total weight is reached on the front tires. Front weights and weight carriers can be purchased through an authorized tractor dealership. OPS-U- 0005

## **3.7 Power Take Off (PTO)**

Depending on the unit, the mower is designed to operate at a PTO speed of 540 or 1000 RPM. Most tractors operate at either 540, or a combination of 540 and 1000 RPM PTO speeds. The operating speed of the mower and tractor can be determined by the number of splines on the driveline yoke and PTO output shaft. Those operating at 540 RPM will have a 6-spline shaft and those operating at 1000 RPM will have a 21-spline shaft or a 1-3/4" 20 spline shaft. Refer to the tractor owner's manual for instructions to change PTO speeds on models that operate at more than one speed.

If operating an older model tractor where the tractor's transmission and PTO utilize one master clutch, an over-running clutch must be used between the PTO output shaft and the driveline of the mower. An authorized tractor dealer can provide the over-running clutch and its installation if needed. OPS-U- 0006

# OPERATION

**⚠ DANGER**

**DO NOT** use a PTO adapter to attach a non-matching Implement driveline to a Tractor PTO. Use of an adapter can double the operating speed of the Implement resulting in excessive vibration, thrown objects, and blade and implement failure. Adapter use will also change the working length of the driveline exposing unshielded driveline areas. Serious bodily injury and/or equipment failure can result from using a PTO adapter. Consult an authorized dealer for assistance if the Implement driveline does not match the Tractor PTO. (S3PT-14)

**⚠ WARNING**

Never operate the Tractor and Mower if the Implement input driveline is directly connected to the Tractor transmission. Tractor braking distances can be substantially increased by the momentum of the rotating Mower blades driving the Tractor transmission even though the Tractor clutch has been disengaged. Install an over running clutch between the Tractor PTO and the Mower driveline to prevent this potentially dangerous situation. (S3PT-16)

## **4. GETTING ON AND OFF THE TRACTOR**

Before getting onto the tractor, the operator must read and completely understand the implement and tractor operator manuals. If any part of either manual is not completely understood, consult an authorized dealer for a complete explanation. *OPS-U- 0007*

**⚠ WARNING**

Do not mount the Tractor while the tractor is moving. Mount the Tractor only when the Tractor and all moving parts are completely stopped. (SG-12)



### **4.1 Boarding the Tractor**

Use both hands and equipped handrails and steps for support when boarding the tractor. Never use control levers for support when mounting the tractor. Seat yourself in the operator's seat and secure the seat belt around you.

Never allow passengers to ride on the tractor or attached equipment. Riders can easily fall off and be seriously injured or killed from falling off and being ran over. It is the operator's responsibility to forbid all extra riders at all times. *OPS-U- 0008*

**⚠ DANGER**

Never allow children to operate, ride on, or come close to the Tractor or Implement. Usually, 16-17 year-old children who are mature and responsible can operate the implement with adult supervision, if they have read and understand the Operator's Manuals, been trained in proper operation of the tractor and Implement, and are physically large enough to reach and operate the controls easily. (SG-11)





# OPERATION



Never allow children or other persons to ride on the Tractor or Implement. Falling off can result in serious injury or death. (SG-10)



## 4.2 Dismounting the Tractor

Before dismounting, park the tractor and implement on a reasonably level surface, apply the parking brake, idle the engine down, disengage the PTO, and lower the implement to the ground. Shut down the tractor engine according to the operator's manual, remove the key, and wait for all motion to completely stop. Never leave the seat until the tractor, its engine and all moving parts have come to a complete stop.

Use hand rails and steps when exiting the tractor. Be careful of your step and use extra caution when mud, ice, snow or other matter has accumulated on the steps or hand rails. Use all handrails and steps for support and never rush or jump off the tractor. OPS-U- 0009



BEFORE leaving the tractor seat, always engage the brake and/or set the tractor transmission in parking gear, disengage the PTO, stop the engine, remove the key, and wait for all moving parts to stop. Place the tractor shift lever into a low range or parking gear to prevent the tractor from rolling. Never dismount a Tractor that is moving or while the engine is running. Operate the Tractor controls from the tractor seat only. (SG-9)

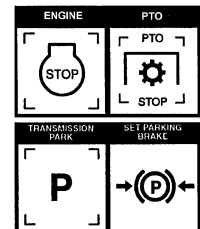

# OPERATION

## 5. STARTING THE TRACTOR

The operator must have a complete understanding of the placement, function, and operational use of all tractor controls before starting the tractor. Review the tractor operator's manual and consult an authorized dealer for tractor operation instructions if needed.

Essential Tractor Controls:

- Locate the light control lever.
- Locate the engine shut off control.
- Locate the brake pedals and the clutch.
- Locate the PTO control.
- Locate the 3-point hitch control lever.
- Locate the hydraulic remote control levers.

Before starting the tractor ensure the following:

- Conduct all pre-start operation inspection and service according to the tractor operator's manual.
- Make sure all guards, shields, and other safety devices are securely in place.
- The parking brake is on.
- The PTO control lever is disengaged.
- The 3-point hitch control lever is in the lowered position.
- The hydraulic remote control levers are in the neutral position.
- The tractor transmission levers are in park or neutral.

Refer to the tractor owner's manual for tractor starting procedures. Only start the tractor while seated and belted in the tractor operator's seat. Never bypass the ignition switch by short circuiting the starter solenoid.

After the tractor engine is running, avoid accidental contact with the tractor transmission to prevent sudden and unexpected tractor movement. *OPS-U-0028*



Start tractor only when properly seated in the Tractor seat. Starting a tractor in gear can result in injury or death. Read the Tractor operators manual for proper starting instructions. (SG-13)



## 6. CONNECTING THE MOWER TO THE TRACTOR

Use extreme caution when connecting the mower to the tractor. The mower should be securely resting at ground level or setting on blocks. Keep hands and feet from under the mower deck and clear of pinch points between the tractor hitch arms and mower pins. *OPS-R-0001*



Never stand or allow another person to stand between a running Tractor and the Mower when attaching the Implement to the Tractor. Always shut the Tractor completely off before attempting to connect the Mower pins to the Tractor hitch.

# OPERATION



Always shut the Tractor completely down, place the transmission in park, and set the parking brake before you or anyone else attempts to connect or disconnect the Implement and Tractor hitches. (S3PT-15)

## 6.1 Connecting the Mower - Lift-Type

1. Make sure the tractor is equipped with the correct PTO shaft. Change shafts if needed.
2. Shorten or remove the tractor drawbar to avoid interference when raising and lowering the mower.
3. Board the tractor and start the engine. Position the tractor to the mower with the 3-point lift arms positioned between the respective set of mower A-frame lift lugs.

**NOTE:** Set the 3-point lift control to "Position Control" so that the lift arms maintain a constant height when attaching the mower. See the tractor Operator's Manual for correct settings when attaching 3-point equipment.



4. Turn off the tractor engine and dismount.
5. One lift arm at a time, align arm end hole between the set of A-frame lift lugs. Insert hitch pin through the lug and arm holes and insert retaining pin into hitch pin.
6. Walk around to opposite side and repeat procedure for remaining lift arm and hitch pin.
7. Extend or retract 3-point top link to align its end hole with the holes of the mower's top link. Insert the top link hitch pin and insert retaining pin into hitch pin.
8. Adjust any lower link check chains, guide blocks, or sway blocks to prevent the mower from swaying side to side and possible contact with tractor rear tires.



**NOTE:** Offset Adaptor Hitches are available to position the mower to the left or right. Mowers with Offset Adaptor hitches connect to the 3-Point hitch the same way as the mower A-frame. See Offset Adaptor Hitch in the Assembly Section for details to equip the mower with this feature.

# OPERATION

## 6.2 Connecting the Mower - Pull-Type

1. Make sure the tractor is equipped with the correct PTO shaft and the drawbar is extended 14" from the end of the PTO shaft to the hitch point.

2. Block the mower wheels in place and use the attached parking jack to raise or lower the tongue clevis to the height of the tractor drawbar. The parking jack can be rotated 15 degrees in each direction to obtain a near vertical position.

**NOTE:** Always place jack foot on firm surface or place board under jack for support.

3. Board the tractor and start the engine. Back the tractor to the mower aligning the drawbar hitch hole with the mower hitch clevis. Turn off the engine, secure the tractor in position, and dismount.

4. To attach the mower, place two 1" flatwashers (1) positioned under top lip of tongue clevis and to the top of drawbar. Add additional 1" flatwashers (2) between the bottom of drawbar and bottom lip of clevis to fill open space. Insert a 3/4" x 4-1/2" grade 5 or 8 bolt (3) through clevis and drawbar and retain in position with a 1" locknut (4). The bolt and locknut should be tightened securely to support the tongue properly without springing of breaking the clevis. Never attach mower to the tractor with a pin not having a nut.

5. Securely attach mower safety chain from mower tongue to tractor drawbar or drawbar support frame.

6. Lower the jack until the tongue is completely supported by the drawbar. Remove jack from the tongue and place on storage bracket of mower main frame.

7. If using a hydraulic cylinder, connect hydraulic hose ends into tractor hydraulic ports. Pressure may need to be relieved from the system to allow for ease of attachment.

8. If the mower has been attached to a 3-point hitch drawbar, adjust any tractor equipped lower link check chains, guide blocks, or sway blocks to prevent the hitch and mower from swaying side to side.

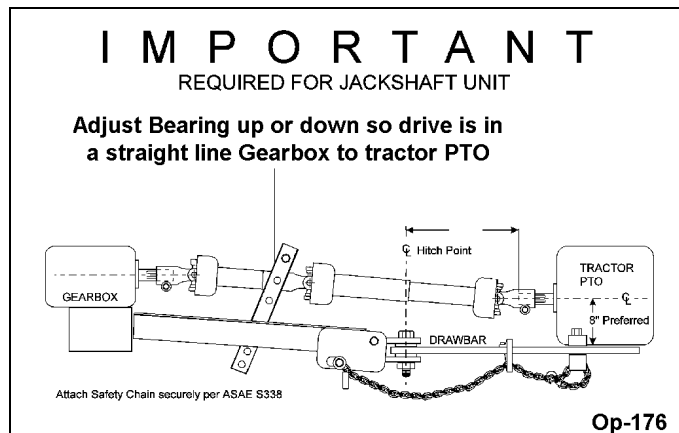
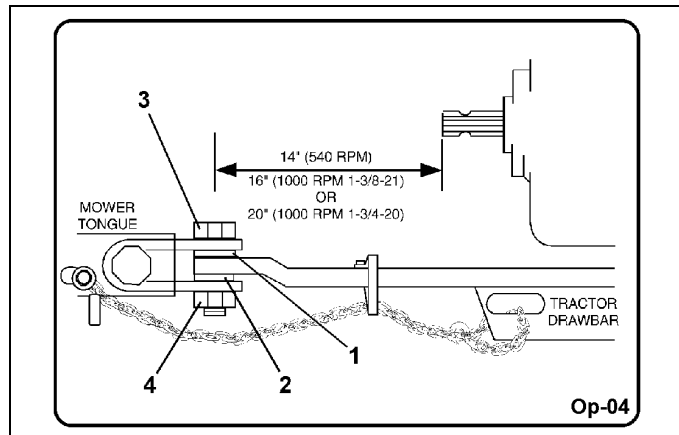
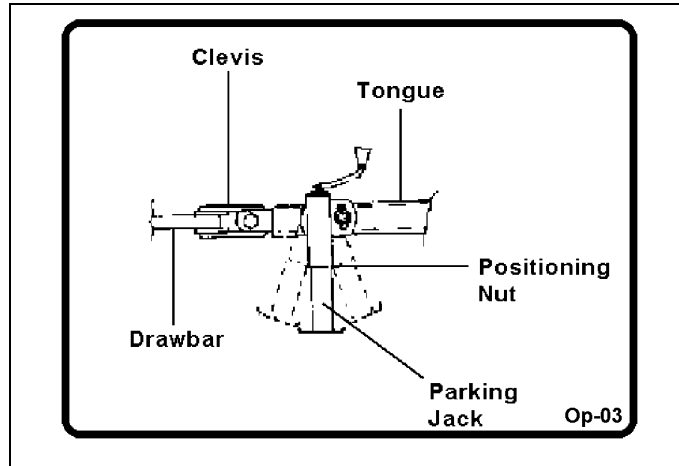

**NOTE:** Never raise the 3-point lift with the mower attached as catastrophic driveline damage will occur.

# OPERATION

## Safety Chains

When towing implements on a public roadway, use a safety chain with tensile strength equal to or greater than the gross weight of the unit being towed. This will control the implement in the event the hitch pin is lost during transport.

After the ends of the safety chain are attached to the implement and the tractor, make a trial run by driving the tractor to the right and to the left to check for proper length. If necessary, readjust the chain to eliminate loose or tight chain lengths.

## 7. SETTING THE MOWER

Properly setting the cutting height is essential for efficient and safe operation. A properly set mower will make a more uniform cut, distribute clippings more evenly, require minimal tractor work, and follow the contour of uneven terrain. **NOTE:** Avoid very low cutting heights, striking the ground with the blades gives the most damaging shock loads and will cause damage to the mower and drive. Blades contacting the ground may cause objects to be thrown out from under the mower deck. Always avoid operating the mower at a height which causes the blades to contact the ground. OPS-U- 0010

### 7.1 Setting Mower Height - Lift-Type

1. Park the tractor and mower on level ground.
2. Using the 3-point hitch control lever, position the front of the mower with the side skids 1" less off the ground than desired cut height. For example, for a 3" cut, position the skids 2" from the ground. Set the 3-point control lever stop at this position to maintain this height when raising and lowering the mower.
3. Shut down the tractor and remove the key.
4. Level the mower deck front to rear by extending or retracting the 3-point top link.
5. Level the mower side to side by manipulating one lower lift arm length. On most tractors, at least one of the lift arms is designed to allow for manipulation of its length. Shortening or extending will allow for deck leveling from side to side.
6. Securely block up the mower at this height.
7. Remove the bolts securing the tail wheel beam positioning bracket to the support brackets and allow the tail wheel to rest at ground level. Align beam and positioning brackets holes with closest set of holes in support brackets and reinstall bolts securing the beam in position. Tighten all bolts and nuts.



# OPERATION

8. Extend the tractor's top 3-point link so that when lifting the mower, the front of the deck will raise 2 to 2½" before the tail wheel leaves the ground. This will allow the mower to follow the contour of uneven terrain.

**NOTE:** Install optional check chains when there is a problem with the hydraulic 3-Point lift maintaining a set height or when a constant pre-adjusted cut height is required. See Check Chains in the Assembly Section for this accessory.



## 7.2 Setting Mowing Height - Pull-Type

1. Park the tractor and mower on level ground.
2. Using the tail wheel ratchet jack or hydraulic cylinder, position the mower so the skid shoes are 1" less off the ground than the desired final cut height. For example, if a 3" cut is desired, raise or lower the mower until the skid shoes are 2" off the ground. If a hydraulic cylinder is used, stroke control spacers can be placed on the hydraulic shaft to maintain a set cutting height each time the mower is raised and lowered.
3. Adjust the mower leveling rod so that the front of the mower is approximately 3/4" lower than the rear.
4. If the mower is attached to a 3-point hitch drawbar, adjust any tractor equipped lower link check chains, guide blocks, or sway blocks to prevent the hitch and mower from swaying from side to side. Never raise the 3-point lift with the mower attached as catastrophic driveline damage will occur.

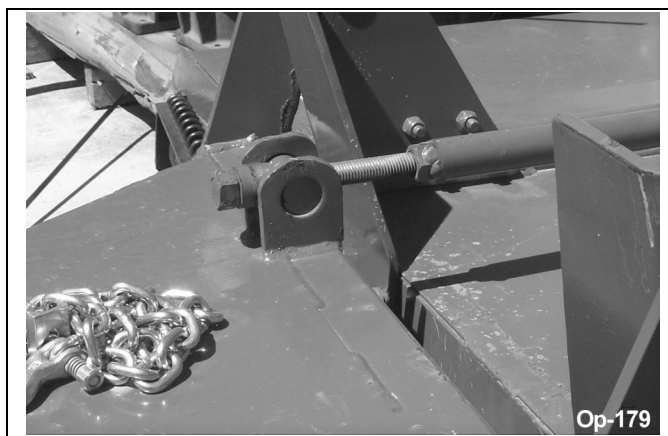

# OPERATION

## 7.3 Setting Deck Pitch

To facilitate safe and efficient operation, the mower should be operated with the deck approximately 3/4" LOWER IN THE FRONT THAN THE REAR.

Operating the mower at this pitch will allow the mower to cut the grass only once and requires less work from the tractor. In addition, a more even distribution of the clippings from the rear of the mower will be achieved with this deck pitch.

Adjust the leveling rods linking the tongue to the rear axle until the front of the mower is at least 3/4" lower in the front than that than the rear. To lower the front, lengthen the leveling rods and to raise the front shorten the leveling rods. **IMPORTANT:**

*Adjust the leveling rods the same amount and maintain equal tension in the rods. Improper adjustment may cause rods to snap or bend. Retighten the jamnuts after the deck pitch has been set. OPS-R-0002*

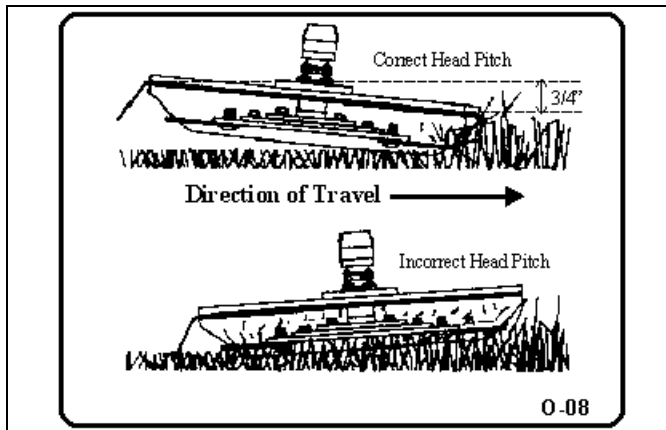

### Setting Deck Pitch - Lift-Type

1. Lower the mower until the rear of the mower is resting securely on its tail wheels.
2. Lower the 3-point lift arms further until the front of the mower is at least 3/4" lower than the rear.
3. Place the tractor's 3-point control lever stop at this point to maintain the deck pitch.

### Setting Deck Pitch - Pull-Type

1. Adjust the leveling rods linking the tongue to the rear axle until the front of the mower is at least 3/4" lower in the front than the rear. To lower the front, lengthen the leveling rods and to raise the front, shorten the leveling rods.

## 8. DRIVELINE ATTACHMENT

The driveline yoke and tractor PTO shaft must be dirt free and greased for attachment.

To connect the mower driveline to the tractor PTO output shaft, pull the driveline yoke collar back and align the grooves and splines of the yoke with those of the PTO shaft. Push the driveline yoke onto the PTO shaft, release the locking collar, and position the yoke until the locking collar balls are seated onto the PTO shaft. Push and pull the driveline back and forth several times to ensure a secure attachment. OPS-R-0003\_A

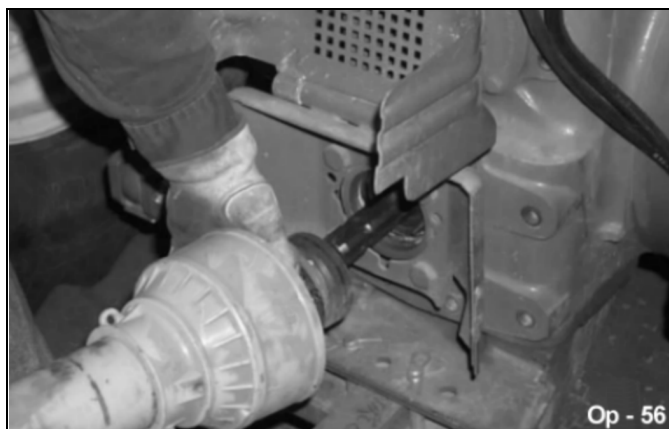

# OPERATION



When attaching the Implement input driveline to the Tractor PTO, it is important that the connecting yoke spring activated locking collar slides freely and the locking balls are seated securely in the groove on the Tractor PTO shaft. A driveline not attached correctly to the Tractor PTO shaft could come loose and result in personal injury and damage to the Implement. (S3PT-17)

## 8.1 Driveline Length Check



Before operating the Implement, check to make sure the Implement input driveline will not bottom out or become disengaged. Bottoming out occurs when the inner shaft penetrates the outer housing until the assembly becomes solid-it can shorten no more. Bottoming out can cause serious damage to the Tractor PTO by pushing the PTO into the Tractor and through the support bearings or downward onto the PTO shaft, breaking it off. A broken driveline can cause personal injury. (S3PT-18)

OPERATION

When fitting the mower to the tractor, the telescoping driveline must be inspected to ensure that at its most compressed position, the profiles do not “bottom out”, and when at its farthest extended position, there is sufficient engagement between the profiles to operate safely. At its shortest length, there must be at least a 1” clearance between each profile end and opposite profile universal joint. At its farthest operating extension, a minimum profile engagement of 9” must be maintained.

### “Bottoming Out” Check Procedure

- Disconnect driveline from the tractor and slide the profiles together until fully compressed.
- Place a mark on the inner shield 1/8” from the end of the outer shield.
- Reattach the driveline to the PTO Shaft.
- **Lift Type** - With the PTO NOT TURNING, raise and lower the mower and watch shaft movement.
- **Pull Type** - With the PTO NOT TURNING, drive the tractor and mower through the sharpest turn possible and watch shaft movement. With the PTO NOT TURNING, drive the tractor and mower through the most severe terrain conditions expected and watch shaft movement.

- Raise the mower and watch the driveline as it approaches the mark. If the distance between the mark and the end of the outer shield tube becomes less than 2” at any point, contact your local dealer or tech service for proper directions. OPS-R-0004\_B

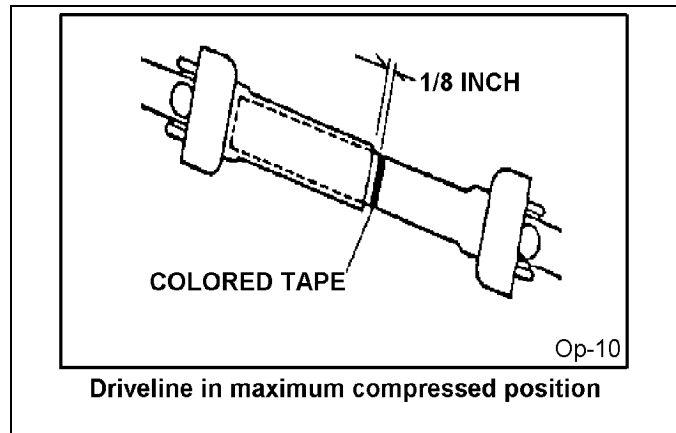



# OPERATION

## Engagement Check Procedure

- With the driveline attached, position the mower to the point where the telescoping driveline is at its maximum extension. Turn off the tractor and securely block the mower at this position.
- Mark the inner driveline shield 1/8" from the end of the outer shield.
- Disconnect the driveline from the tractor and separate the two driveline halves.
- Measure the distance from the mark to the end of the inner profile. This length is the amount the driveline profiles were engaged.
- If the engaged length is less than 9", the shaft is considered too short and should be replaced with a longer shaft. Consult an authorized dealer to purchase the required driveline length.

**NOTE:** When raising the mower, at least 1" clearance must be maintained between the driveline and the mower deck. If necessary, place an upper lift stop on the 3-point hitch control lever to limit the height the mower can be raised. OPS-R-0005\_B

## 9. PRE-OPERATION INSPECTION AND SERVICE

Before each use, a pre-operation inspection and service of the implement and tractor must be performed. This includes routine maintenance and scheduled lubrication, inspecting that all safety devices are equipped and functional, and performing needed repairs. DO NOT operate the unit if the pre-operation inspection reveals any condition affecting safe operation. Perform repairs and replacement of damaged and missing parts as soon as noticed. By performing a thorough pre-operation inspection and service, valuable down time and repair cost can be avoided. OPS-U-0029

### **▲ DANGER**

Always disconnect the main PTO Driveline from the Tractor before performing service on the Implement. Never work on the Implement with the tractor PTO driveline connected and running. Rotating Parts, Blades or Drivelines could turn without warning and cause immediate entanglement, injury or death. (S3PT-11)

### **▲ DANGER**

Never work under the Implement, the framework, or any lifted component unless the Implement is securely supported or blocked up to prevent sudden or inadvertent falling which could cause serious injury or even death. (SG-14)



### **▲ WARNING**

Periodically inspect all moving parts for wear and replace when necessary with authorized service parts. Look for loose fasteners, worn or broken parts, and leaky or loose fittings. Make sure all pins have cotter pins and washers. Serious injury may occur from not maintaining this machine in good working order. (SG-21)

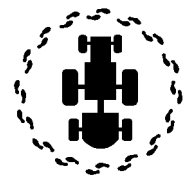

# OPERATION

## **9.1 Tractor Pre-Operation Inspection/Service**

Refer to the tractor operator's manual to ensure a complete pre-operation inspection and scheduled service is performed according to the manufacturers recommendations. The following are some of the items that require daily service and inspection:

- Tire condition/air pressure
- Wheel lug bolts
- Steering linkage
- PTO shield
- SMV sign is clean and visible
- Tractor's lights are clean and functional
- Tractor Seat belt is in good condition
- Tractor ROPS is in good condition
- ROPS is in the raised position
- No tractor oil leaks
- Radiator free of debris
- Engine oil level and condition
- Engine coolant level and condition
- Power brake fluid level
- Power steering fluid level
- Fuel condition and level
- Sufficient lubrication at all lube points
- Air filter condition *OPS-U-0030*



## **9.2 Mower Pre-Operation Inspection/Service**

Before each mower use, a complete inspection and service is required to ensure the mower is in a good and safe working condition. Damaged and/or broken parts should be repaired and/or replaced immediately. To ensure the mower is ready for operation, conduct the following. *OPS-R-0007*

- Perform scheduled lubrication as detailed in the maintenance section.
- Ensure all decals are in place and legible.
- Ensure the driveline is securely attached to tractor. Make sure the driveline yoke locking collar is securely seated in the grooves of the PTO shaft by pushing and pulling the yoke several times.
- Lift Type - Inspect that the 3-point hitch pins are the proper size, correctly installed, and secured to the tractor lift arms with retaining pins inserted.
- Pull Type - Inspect that the hitch bolt is the correct size, that washers are inserted between the drawbar and hitch clevis, and the locknut is securely tightened. *OPS-R-0037\_A*



# OPERATION

- Ensure deflectors and/or chainguards are in position and not damaged. Replace worn, broken, and missing pieces. *OPS-R-0038*



All Safety Shields, Guards and Safety devices including (but not limited to) - the Deflectors, Chain Guards, Steel Guards, Gearbox Shields, PTO integral shields, and Retractable Door Shields should be used and maintained in good working condition. All safety devices should be inspected carefully at least daily for missing or broken components. Missing, broken, or worn items must be replaced at once to reduce the possibility of injury or death from thrown objects, entanglement, or blade contact. (SGM-3)

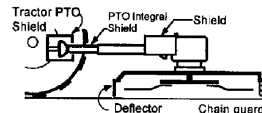

- Lift-Type - Ensure the tailwheel beam position support bolts are properly installed and tightened.
- Pull-Type - Ensure that the tailwheel ratchet or hydraulic cylinder is installed and retained correctly to provide the desired cutting height.
- Inspect all bolts and screws and tighten to the recommended torque. *OPS-R-0045*



OPERATION

# OPERATION

## OPERATION

- Ensure the tractor PTO master shield and the mower slip clutch shield are in place, lowered, and in good condition.
- Ensure the driveline integral shield is in good condition and rotates freely.
- Ensure the driveline slip clutch (if equipped) is properly adjusted. *OPS-R-0039*



- Inspect the gearbox oil level. A low oil level is a warning sign that the gearbox may be cracked or its seal is damaged and needs replacement.
- Ensure the gearbox vent is in place and free from clogs. *OPS-R-0040*



- Inspect blades and blade bolts for looseness and excessive wear. Make sure the mower is securely blocked up before crawling beneath. Replace damaged, worn and missing blades as complete sets to maintain rotary balance during operation.
- Ensure carrier hub nut is tightened with the cotter pin inserted and spread. *OPS-R-0041*



### **⚠ DANGER**

Replace bent or broken blades with new blades. NEVER ATTEMPT TO STRAIGHTEN, WELD, OR WELD HARDFACING ON BLADES SINCE THIS WILL LIKELY CRACK OR OTHERWISE DAMAGE THE BLADE WITH SUBSEQUENT FAILURE AND POSSIBLE SERIOUS INJURY FROM THROWN BLADES. (SGM-10)

# OPERATION

## 9.3 Cutting Component Inspection

Inspect blade pan and blade assembly for the following:

OPS-U-0031

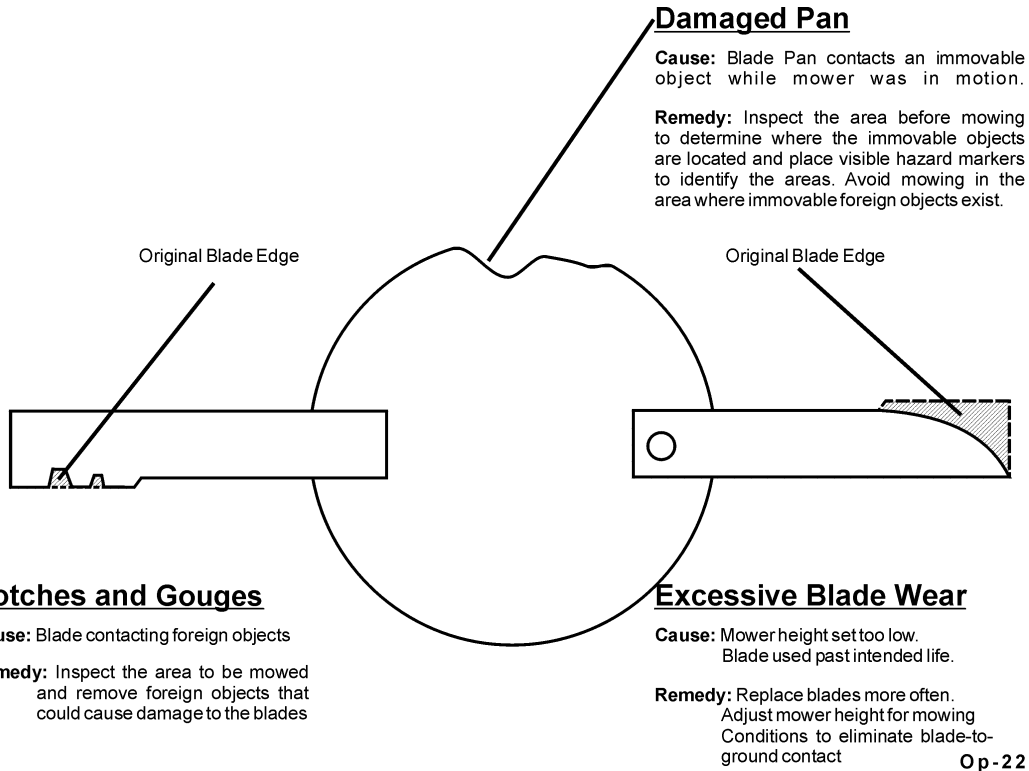

Inspect the Blades daily for abnormal wear. REPLACE BOTH BLADES on that carrier IMMEDIATELY if either blade has:

- Become bent or deformed from it's original shape or
- Any cracks are visible, or
- Deep gouges in the blade's surface are present, or
- Gouges or chipped areas in the cutting edge are larger than 1/2"(12.7mm), or
- The material on the leading edge has been worn away by more than 1/2(12.7mm)"

Failure to replace abnormally worn blades may lead to catastrophic failure of the blades and ejection of the broken part with tremendous force which may cause serious bodily injury or death. OPS-U-0032

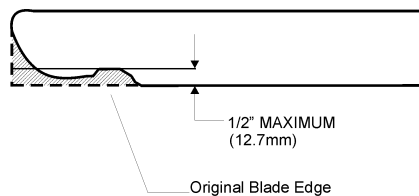

**NOTE:**  
Replace Blades in pairs after no more than 1/2" (12.7mm) wear  
Op - 23

# OPERATION

OPERATION

## 9.4 Blade Bolt Inspection

Inspect Blade Bolt Head daily for wear as followed:

### Excessive Blade Bolt Wear

**Cause:** Blade Bolt contacts a foreign or solid object while Blade is in motion.

**Remedy:** Inspect the area before mowing to determine where the foreign objects are located and place visible hazard markers to identify the areas where immovable foreign objects exist, and avoid hitting the objects

### Notches and Gouges

**Cause:** Blade Bolt contacting foreign objects

**Remedy:** Inspect area to be mowed and remove foreign objects that could cause damage to the blade bolts.

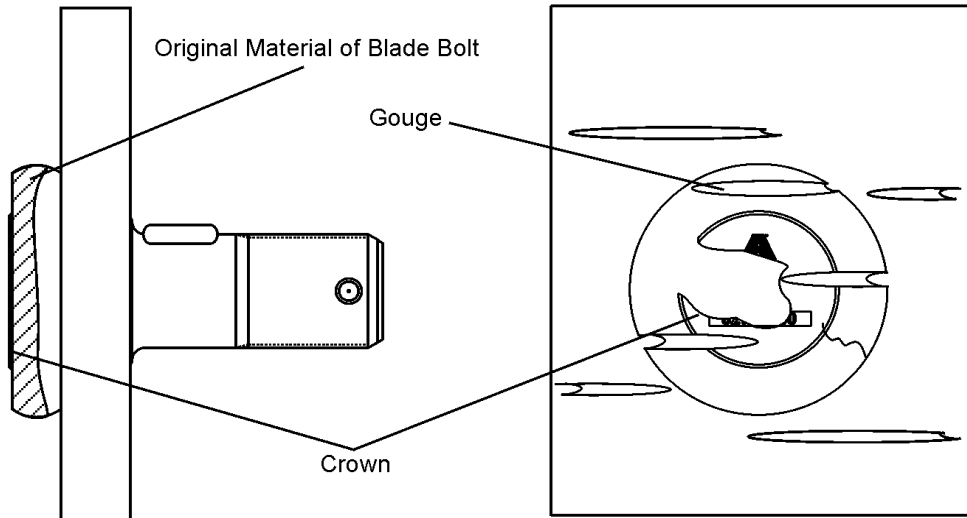

Inspect the Blade Bolt Heads daily for abnormal wear. REPLACE BOTH BLADE BOLTS on the Blades IMMEDIATELY if either blade bolts has:

- Visible cracks or
- If the blade bolt crown is worn off or
- If Blade Bolt has gouges or chipped areas.

Failure to replace abnormally worn blade bolts may lead to catastrophic failure of the blades and ejection of the broken part which may cause serious bodily injury or death.

**Always replace Blade Bolts with new bolts whenever replacing the Blades. OPS-U-0037**

# OPERATION

## Tractor PRE-OPERATION Inspection



Mower ID# \_\_\_\_\_ Make \_\_\_\_\_

Date: \_\_\_\_\_ Shift \_\_\_\_\_



**Before conducting the inspection, make sure the tractor engine is off, all rotation has stopped and the tractor is in park with the parking brake engaged. Make sure the mower is resting on the ground or securely blocked up and all hydraulic pressure has been relieved.**

| Item   | Condition at Start of Shift | Specific Comments if not O.K. |
|--|-----------------------------|-------------------------------|
| The flashing lights function properly                |                             |                               |
| The SMV Sign is clean and visible                    |                             |                               |
| The tires are in good condition with proper pressure |                             |                               |
| The wheel lug bolts are tight                        |                             |                               |
| The tractor brakes are in good condition             |                             |                               |
| The steering linkage is in good condition            |                             |                               |
| There are no visible oil leaks                       |                             |                               |
| The hydraulic controls function properly             |                             |                               |
| The ROPS or ROBS Cab is in good condition            |                             |                               |
| The seatbelt is in place and in good condition       |                             |                               |
| The 3-point hitch is in good condition               |                             |                               |
| The drawbar pins are securely in place               |                             |                               |
| The PTO master shield is in place                    |                             |                               |
| The engine oil level is full                         |                             |                               |
| The brake fluid level is full                        |                             |                               |
| The power steering fluid level is full               |                             |                               |
| The fuel level is adequate                           |                             |                               |
| The engine coolant fluid level is full               |                             |                               |
| The radiator is free of debris                       |                             |                               |
| The air filter is in good condition                  |                             |                               |

Operator's Signature: \_\_\_\_\_

**DO NOT OPERATE an UNSAFE TRACTOR or MOWER**

**OPERATION**

# OPERATION

## Rotary Mower PRE-OPERATION Inspection



Mower ID# \_\_\_\_\_ Make \_\_\_\_\_

Date: \_\_\_\_\_ Shift \_\_\_\_\_



**Before conducting the inspection, make sure the tractor engine is off, all rotation has stopped and the tractor is in park with the parking brake engaged. Make sure the mower is resting on the ground or securely blocked up and all hydraulic pressure has been relieved.**

**OPERATION**

| Item   | Condition at Start of Shift | Specific Comments if not O.K. |
|--|-----------------------------|-------------------------------|
| The Operator's Manual is in the canister on the mower    |                             |                               |
| All safety decals are in place and legible               |                             |                               |
| The tongue/hitch connection bolts & pins are tight       |                             |                               |
| There are no cracks in tongue or hitch                   |                             |                               |
| The tow chain is secured to the tractor & mower          |                             |                               |
| The hydraulic cylinders pins are tight                   |                             |                               |
| There are no leaking or damaged hoses                    |                             |                               |
| The mower deck is clear of cut grass and debris          |                             |                               |
| Chain guards/deflectors are in place & in good condition |                             |                               |
| Driveline/gearbox shields are in good condition          |                             |                               |
| Driveline clutches are in good condition; not frozen     |                             |                               |
| Driveline telescoping members & U-joints are lubricated  |                             |                               |
| Driveline yokes are securely attached to PTO & mower     |                             |                               |
| Gearbox mounting bolts are tight                         |                             |                               |
| Gearbox oil is at the proper level                       |                             |                               |
| Blade carrier retaining nut is tight                     |                             |                               |
| Blades are not chipped, cracked or bent                  |                             |                               |
| Blade bolts are tight                                    |                             |                               |
| Wheel lug nuts are tight                                 |                             |                               |
| Transport locks are in good condition                    |                             |                               |

Operator's Signature: \_\_\_\_\_

**DO NOT OPERATE an UNSAFE TRACTOR or MOWER**



# OPERATION

## 10. DRIVING THE TRACTOR AND IMPLEMENT

Safe tractor transport requires the operator possess a thorough knowledge of the model being operated and precautions to take while driving with an attached implement. Ensure the tractor has the capacity to handle the weight of the implement and the tractor operating controls are set for safe transport. To ensure safety while driving the tractor with an attached implement, review the following. *OPS-U- 0012*



Never run the Tractor engine in a closed building or without adequate ventilation. The exhaust fumes can be hazardous to your health. (SG-23)



Transport only at speeds where you can maintain control of the equipment. Serious accidents and injuries can result from operating this equipment at high speeds. Understand the Tractor and Implement and how it handles before transporting on streets and highways. Make sure the Tractor steering and brakes are in good condition and operate properly.



Before transporting the Tractor and Implement, determine the proper transport speeds for you and the equipment. Make sure you abide by the following rules:

Test the tractor at a slow speed and increase the speed slowly. Apply the Brakes smoothly to determine the stopping characteristics of the Tractor and Implement. As you increase the speed of the Tractor the stopping distance increases. Determine the maximum transport speed not to exceed 20 mph (30 kph) for transporting this equipment.

Test the equipment at a slow speed in turns. Increase the speed through the turn only after you determine that the equipment can be operated at a higher speed. Use extreme care and reduce your speed when turning sharply to prevent the tractor and implement from turning over. Determine the maximum turning speed for you and this equipment before operating on roads or uneven ground.

Only transport the Tractor and Implement at the speeds which allow you to properly control the equipment.

Be aware of the operating conditions. Do not operate the Tractor with weak or faulty brakes or worn tires. When operating down a hill or on wet or rain slick roads, the braking distance increases: use extreme care and reduce your speed. When operating in traffic always use the Tractor's flashing warning lights and reduce your speed. Be aware of traffic around you and watch out for the other guy. (SG-19)



# OPERATION

## **10.1 Starting the Tractor**

The procedure to start the tractor is model specific. Refer to the tractor operator's manual for starting procedures for your particular tractor. Consult an authorized dealer if the starting procedure is unclear. Ensure the 3-point control lever is in the lowered position and the PTO is disengaged before starting the tractor. OPS-U-0033



## **10.2 Brake and Differential Lock Setting**

Make sure the tractor brakes are in good operating condition. Tractor brakes can be set to operate independently allowing single rear wheel braking action or locked together to provide simultaneous rear wheel braking. FOR MOST DRIVING AND OPERATING CONDITIONS, THE BRAKE PEDALS SHOULD BE LOCKED TOGETHER TO PROVIDE THE MOST EFFECTIVE BRAKING ACTION.

Always disengage the tractor differential lock when turning. When engaged the differential lock will prevent or limit the tractor from turning. During normal cutting conditions, locking the differential provides no benefit and should not be used. OPS-U-0013



### **▲WARNING**

Be aware of the operating conditions. Do not operate the Tractor with weak or faulty brakes. When operating down a hill or on wet or rain slick roads, the braking distance increases; use extreme care and reduce your speed in these conditions. When operating in traffic, always use the Tractor's flashing warning lights and reduce your speed. Be aware of traffic around you and watch out for the other guy.

# OPERATION

## **10.3 Raising the Mower**

Using the tractor 3-point hitch control lever, raise the mower off the ground about 6", or just high enough to clear any ground obstacles. When raising the mower, make sure all connection points are securely attached and at least 1" clearance is maintained between the driveline and the deck. If necessary, place an upper lift stop on the 3-point hitch control lever to limit the height the mower can be raised to avoid driveline damage. OPS-R-0042

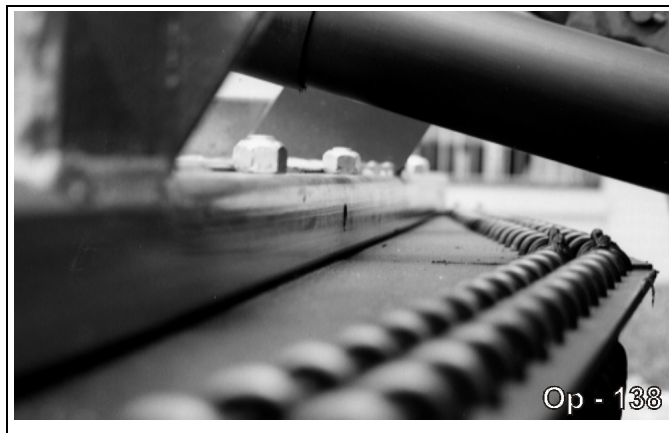

## **10.4 Driving the Tractor and Mower**

Start off driving at a slow speed and gradually increase your speed while maintaining complete control of the tractor and mower. Moving slowly at first will also prevent the tractor from rearing up and loss of steering control. The tractor should never be operated at speeds that cannot be safely handled or which will prevent the operator from stopping quickly during an emergency. If the power steering or engine ceases operating, stop the tractor immediately as the tractor will be difficult to control.

Perform turns with the tractor and mower at slow speeds to determine how the tractor with an attached mower handles a turn. Determine the safe speed to maintain proper control of the tractor when making turns. When turning with a towed implement, the overall working length of the unit is increased. Allow additional clearance for the mower when turning.

To avoid overturns, drive the tractor with care and at safe speeds, especially when operating over rough ground, crossing ditches or slopes, and turning corners. Tractor wheel tread spacing should be increased when working on inclines or rough ground to reduce the possibility of tipping.

Use extreme caution when operating on steep slopes. Keep the tractor in a low gear when going downhill. DO NOT coast or free-wheel downhill. OPS-R-0019



# OPERATION

## **WARNING**

Be particularly careful when transporting the Implement with the Tractor. Turn curves or go up hills only at a low speed and using a gradual steering angle. Rear mounted implements move the center of gravity to the rear and remove weight from the front wheels. Make certain, by adding front ballast, that at least 20% of the tractor's weight is on the front wheels to prevent rearing up, loss of steering control or Tractor tip-over. Slow down on rough or uneven surfaces to prevent loss of steering control which could result in property damage or possible injury. Do not transport unless 3-Point lift lever is fully raised and in the latched transport position. Dropping implement in transport can cause serious damage to the tractor and/or Implement and possibly cause the operator or others to be injured or killed. (S3PT-2)

## OPERATION

### **10.5 Crossing Ditches and Steep Inclines**

When crossing ditches with steep banks or going up sharp inclines, it is possible that the main driveline inner profile will penetrate into the outer housing to its maximum depth until the assembly becomes solid (driveline is at its extreme shortest length). This type of abusive operation can cause serious damage to the tractor and mower drive by pushing the PTO into the tractor and through the support bearings or downward onto the PTO shaft, breaking it off.

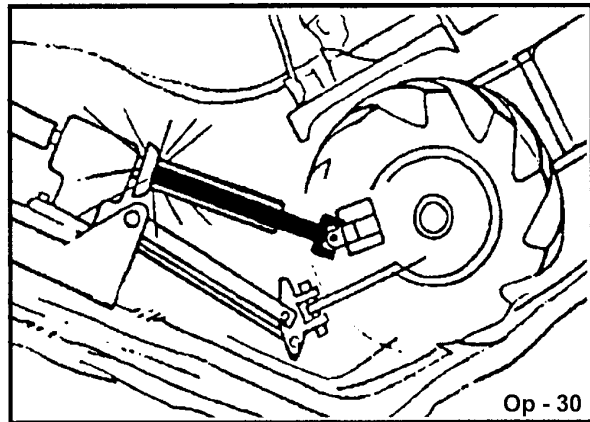

## **WARNING**

Damage resulting from over-collapse of the driveline's inner profile and its outer housing may allow the driveline to come loose from the Tractor which could cause bodily injury to the operator or bystanders and/or extensive damage to the Tractor or Implement. OPS-R-0020

When confronted with an incline or ditch, do not approach from an angle which is perpendicular or straight on as damage to or over-collapse of the driveline may occur. OPS-R-0021\_A

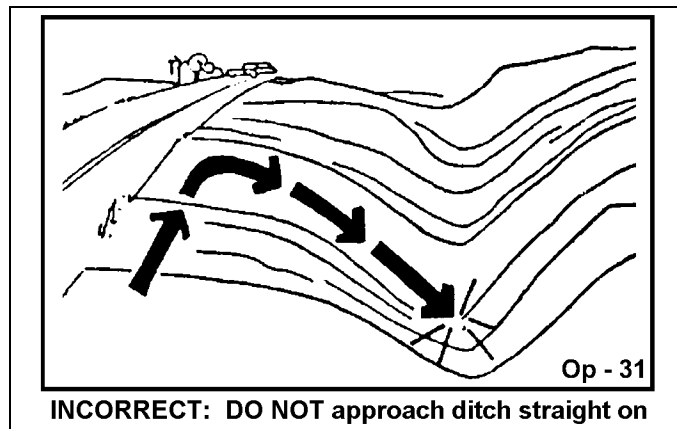

# OPERATION

Inclines and ditches should be approached along a line which is at an angle as shown. This type of path will reduce the possibility of over-collapse of the driveline and resulting damage. If the gradient is so steep that such an approach increases the possibility of a tractor roll-over, select an alternate crossing path.

When operating the tractor and mower across slopes and inclines, through ditches, and other uneven terrain conditions, it is important to maintain sufficient deck to ground clearance. Blade contact with the ground may cause soil, rocks and other debris to be thrown out from under the mower resulting in possible injury and/or property damage. Ground contact also produces a severe shock load on the mower drive and to the mower blades resulting in possible damage and premature wear.  
*OPS-R-0022*

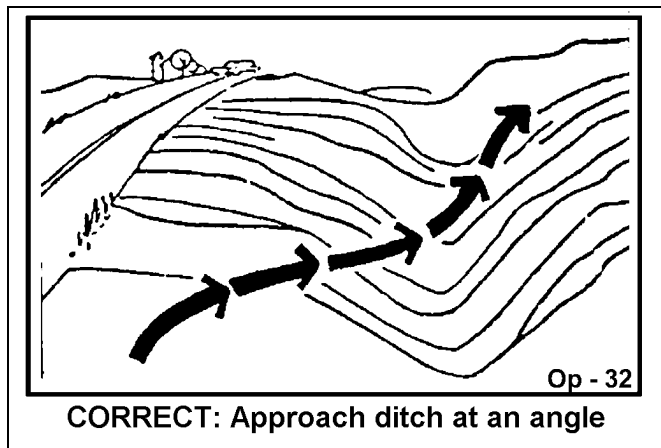

OPERATION

## 11. OPERATING THE TRACTOR AND IMPLEMENT

**THE OPERATOR MUST COMPLETELY UNDERSTAND HOW TO OPERATE THE TRACTOR AND IMPLEMENT AND ALL CONTROLS BEFORE ATTEMPTING TO OPERATE.** The operator must read and understand the Safety and Operation Sections of the implement and tractor operator's manuals. These manuals must be read and explained to any operator who cannot read. Never allow someone to operate the implement and tractor without complete operating instructions.

Before starting any operation, the operator must become familiar with the area to be worked in and any obstacles and hazards contained within to ensure safety to the operator, bystanders, and equipment. Special attention should be paid to foreign debris, rough terrain, steep slopes, and passersby and animals in the area.  
*OPS-U-0015*



Extreme care should be taken when operating near loose objects such as gravel, rocks, wire, and other debris. Inspect the area before mowing. Foreign objects should be removed from the site to prevent machine damage and/or bodily injury or even death. Any objects that cannot be removed must be clearly marked and carefully avoided by the operator. Stop mowing immediately if blades strike a foreign object. Repair all damage and make certain rotor or blade carrier is balanced before resuming mowing. (SGM-5)



# OPERATION



Many varied objects, such as wire, cable, rope, or chains, can become entangled in the operating parts of the mower head. These items could then swing outside the housing at greater velocities than the blades. Such a situation is extremely hazardous and could result in serious injury or even death. Inspect the cutting area for such objects before mowing. Remove any like object from the site. Never allow the cutting blades to contact such items. (SGM-6)

## **11.1 Foreign Debris Hazards**

Before mowing, inspect the area to make sure there are no foreign objects that the mower blades could hit or become entangled with. Remove all foreign objects and debris. If objects are too big to remove, mark them clearly and be sure to prevent the mower blades from contacting them.

If you hit a solid object or foreign debris, stop the mower and tractor at once. Immediately idle the engine speed and disengage the PTO. Wait for all mower rotating motion to stop, then raise the mower and move the tractor and implement off the object. Inspect the area and remove, or mark the location of the debris. Inspect the condition of the mower and make any needed repairs immediately. Make sure the blades are not damaged and the carrier is balanced before resuming operation.

Always wear your seat belt securely fastened and only operate the tractor and mower with the ROPS in the raised position. If the tractor or mower hits a tree stump, rock, or bump, a sudden movement could throw you off of the seat and under the tractor and/or mower. The seat belt is your best protection from falling off the tractor and the ROPS provides protection from being crushed during a tractor roll-over. OPS-R-0023



Op - 33



Op-151

## **11.2 Bystanders/Passersby Precautions**

If a bystander comes within 300 feet of the tractor while the mower is being operated, stop the tractor at once, idle the engine and disengage the PTO. Do not engage the PTO again until all bystanders are well past the 300 foot distance. OPS-R-0024

# OPERATION



Rotary Mowers are capable under adverse conditions of throwing objects for great distances (300 feet or more) and causing serious injury or death. Follow safety messages carefully.



STOP MOWING IF PASSERSBY ARE WITHIN 100 YARDS UNLESS:

- Front and Rear Deflectors, Chain Guards, or Bands are installed and in good, workable condition;
- Mower sections or Wings are running close to and parallel to the ground without exposed Blades;
- Passersby are outside the existing thrown-object zone;
- All areas have been thoroughly inspected and all foreign material such as rocks, cans, glass, and general debris has been removed.

**NOTE:** *Where there are grass and weeds high enough to hide debris that could be struck by the blades, the area should be: inspected and large debris removed, mowed at an intermediate height, inspected, closely with any remaining debris being removed, and mowed again at desired final height. (This will also reduce power required to mow, reduce wear and tear on the Mower drivetrain, spread cut material better, reduce streaking, and make the final cut more uniform).* (SRM-1)

## 11.3 Engaging the Power Take Off (PTO)

Before engaging the PTO, make certain that the area is clear of bystanders and passersby. The implement must be completely lowered and the deck positioned at a safe operating height. NEVER engage the PTO with the implement in the raised position.

Set the tractor engine speed at approximately 1,000 RPM before engaging the PTO. Shift the PTO control to the on position, and slowly increase the engine speed until the PTO is operating at the rated speed. If you hear unusual noises or see or feel abnormal vibrations, disengage the PTO immediately. Inspect the implement to determine the cause of the noise or vibration and repair the abnormality. OPS-U- 0027



Do not let the Blades turn when the Mower Deck is raised for any reason, including clearance or for turning. Raising the Mower deck exposes the Cutting Blades which creates a potentially serious hazard and could cause serious injury or even death from objects thrown from the Blades. (SRM-7)



Do not put hands or feet under mower decks. Blade Contact can result in serious injury or even death. Stay away until all motion has stopped and the decks are securely blocked up. (SGM-9)

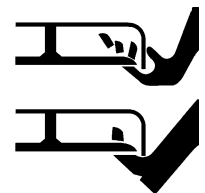

# OPERATION

## **11.4 PTO RPM and Ground Speed**

Ground speed for mowing will depend upon the height, type, and density of vegetation to be cut. Recommended speed for efficient mower performance is between 2 and 5 mph(3-8 kph). Operate the mower at its full rated PTO speed to maintain blade speed for a clean cut. Refer to the tractor operator's manual or the tractor instrument panel for the engine speed and gear to provide the required PTO and desired ground speed. Make sure that the mower is operating at its full rated speed before entering the vegetation to be cut. If it becomes necessary to temporarily regulate engine speed, increase or decrease the throttle gradually.

Ground speed is achieved by transmission gear selection and not by the engine operating speed. The operator may be required to experiment with several gear range combinations to determine the best gear and range which provides the most ideal performance from the mower and most efficient tractor operation. As the severity of cutting conditions increase, the ground speed should be decreased by selecting a lower gear to maintain the proper operating PTO speed. OPS-R-0025



Do not exceed the rated PTO speed for the Implement. Excessive PTO speeds can cause Implement driveline or blade failures resulting in serious injury or death. (SG-26)



Mow at the speed that you can safely operate and control the tractor and mower. The correct mowing speed depends on terrain condition and grass type, density, and height of cut. Normal ground speed range is from 2 to 5 mph(3-8 kph). Use slow mowing speeds when operating on or near steep slopes, ditches, drop-offs, overhead obstructions, power lines, or when debris and foreign objects are to be avoided. (SGM-7)

## **11.5 Operating the Mower**

Only operate the mower from the tractor operator's seat with the seatbelt securely fastened. The tractor must be equipped with a ROPS in the raised position or a ROPS cab.

The mower is designed to cut vegetation up to 3" in diameter. Sharp blades will produce a cleaner cut and require less power. Travel at a speed that allows the mower sufficient time to cut through the vegetation and maintain the PTO operating speed to prevent overloading the mower and tractor. Choose a driving pattern that provides the maximum pass length and minimizes turning.

Under certain conditions, tractor tires may roll some grasses down preventing them from being cut at the same height as the surrounding area. When this occurs, reduce the tractor ground speed while maintaining the operating speed of the mower. A slower ground speed will permit grasses to at least partially rebound and be cut. Taking a partial cut and/or reversing the direction of travel may also help produce a cleaner cut.

Avoid mowing in the reverse direction when possible. In situations where the mower must be backed to access areas to be cut, make sure there are no persons or other foreign debris behind the mower before mowing in reverse. When mowing in reverse, operate the tractor and mower at a reduced ground speed to ensure tractor and mower control is maintained. OPS-R-0026\_A



# OPERATION

## **WARNING**

Do not mow with two machines in the same area except with Cab tractors with the windows closed. (SGM-11)

## **WARNING**

Mow only in conditions where you have clear visibility in daylight or with adequate artificial lighting. Never mow in darkness or foggy conditions where you cannot clearly see at least 100 yards(90 m) in front and to the sides of the tractor and mower. Make sure that you can clearly see and identify passersby, steep slopes, ditches, drop-offs, overhead obstructions, power lines, debris and foreign objects. If you are unable to clearly see these type of items discontinue mowing. (SGM-1)

## **WARNING**

Avoid mowing in reverse direction when possible. Check to make sure there are no persons behind the mower and use extreme care when mowing in reverse. Mow only at a slow ground speed where you can safely operate and control the tractor and mower. Never mow an area that you have not inspected and removed debris or foreign material. (SGM-8)

## **WARNING**

Follow these guidelines to reduce the risk of equipment and grass fires while operating, servicing, and repairing the Mower and Tractor:



- Equip the Tractor with a fire extinguisher in an accesible location.
- Do Not operate the Mower on a Tractor with an underframe exhaust.
- Do Not smoke or have an open flame near the Mower and Tractor.
- Do Not drive into burning debris or freshly burnt areas.
- Ensure slip clutches are properly adjusted to prevent excessive slippage and plate heating.
- Never allow clippings or debris to collect near drivelines, slip clutches, and gearboxes. Periodically shut down the Tractor and Mower and clean clippings and collected debris from the mower deck. (SGM-12)

# OPERATION

When you get to the end of a pass, slightly raise the mower (2-4") before turning. Never raise the mower entirely while the blades are turning. If the mower must be raised higher than 12" from ground level, disengage the tractor PTO and wait for all mower rotation to come to a complete stop before proceeding to raise the mower.

When turning, the angle between the tractor and mower should not be so great that a clattering of the U-joints occurs. Sharp turns can cause premature failure of the joints and place pressure on the tractor PTO shaft and could cause extensive mechanical damage to the mower and tractor. OPS-R-0027\_A



Op - 145

**WARNING**

Do not let the Blades turn when the Mower Deck is raised for any reason, including clearance or for turning. Raising the Mower deck exposes the Cutting Blades which creates a potentially serious hazard and could cause serious injury or even death from objects thrown from the Blades. (SRM-7)



Large, dense, or wet vegetation may need to be mowed in two or more passes to achieve a uniform cut. In such conditions, raise the cutting height to 12" or more on the first pass. OPS-R-0043



Op - 139

# OPERATION

Then lower the mower to the desired height and mow the vegetation a second time. If possible, select a mowing pattern that is at a 90 degree angle to the first pass to reduce streaking for a more uniform cut. *OPS-R-0044*



Stay alert and watch for trees, low hanging limbs, power lines, and other overhead obstacles and solid ground objects while you are operating. Use care to avoid hitting these items. *OPS-R-0028\_A*



OPERATION

# OPERATION

## 11.6 Shutting Down the Implement

To shut down the implement, first bring the tractor to a complete stop. Then slow down the implement by reducing the engine speed before disengaging the PTO. Wait for all motion to stop before proceeding to drive or shut down the tractor.



Park the tractor on a level surface, place the transmission in park or neutral and apply the parking brake, lower the attached implement to the ground, shut down the engine, remove the key, and wait for all motion to come to a complete stop before exiting the tractor. *OPS-U-0016*



## 12. DISCONNECTING THE MOWER FROM THE TRACTOR

Before disconnecting the mower, the PTO must be disengaged and blade rotation at a complete stop. Move the mower to a level storage location and lower it to the ground. If the mower is not resting securely on the ground, block the mower up securely before attempting to disconnect it from the tractor.

Use extreme care to keep feet and hands from under the mower and clear of any pinch points caused by the tractor hitch arms and mower pins. *OPS-R-0030\_A*



Never stand or allow another person to stand between a running Tractor and the Mower when disconnecting the Implement from the Tractor 3-point hitch.

# OPERATION

## **▲ DANGER**

Always shut the Tractor completely down, place the transmission in park, and set the parking brake before you or anyone else attempts to connect or disconnect the Implement and Tractor hitches. (S3PT-15)

## **▲ WARNING**

Never unhitch without using the Tongue Jack. The Tongue is very heavy. Attempting to lift the Tongue without using the Tongue Jack could cause strains or other injury. Allowing the tongue to fall suddenly and unexpectedly could result in crushing injury. Use the Tongue Jack for lifting the Implement only. Overloading the Tongue Jack can cause failure with possible serious bodily injury or even death. (STI-4)

Lift-Type Mower - To disconnect the mower, first extend the tractor 3-point hitch top link to remove tension on the top link hitch pin. When the pin is loose and easy to rotate, remove the pin from the mower. Next remove both lower hitch pins.

Pull-Type Mower - To disconnect the mower, first relieve hydraulic pressure by moving the control lever back and forth several times. Lower the parking jack and raise the mower until the tongue clevis is no longer resting on the tractor drawbar and is supported solely by the jack. Make sure that the jack foot is securely resting at ground level or supported by a block. Then remove the hitch bolt, locknut, and washers. If a hydraulic cylinder was used, remove its hose end from the tractor port and secure it to the mower to prevent contact with dirt.

After disconnecting the 3 lift points, remove the mower driveline from the tractor PTO shaft. Lay the driveline down carefully to avoid damaging the driveline or its shield. Do not let the driveline fall into mud or dirt, which can contaminate the bearing and shorten the life of the driveline. OPS-R-0031\_A

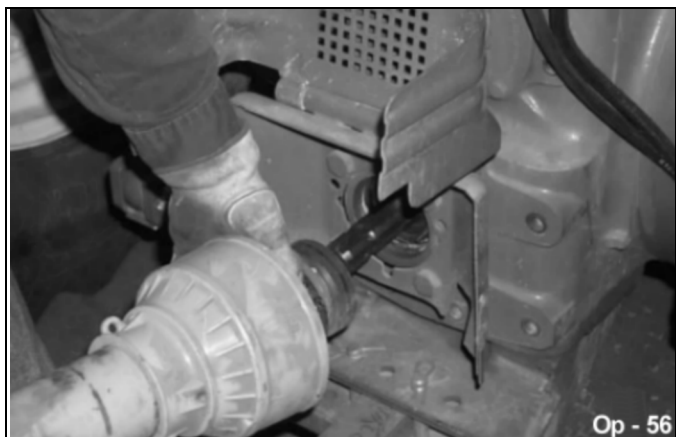

# OPERATION

## 13. MOWER STORAGE

Properly preparing and storing the mower at the end of the season is critical to maintaining its appearance and to help ensure years of dependable service. The following are suggested storage procedures:

- Thoroughly clean all debris off the mower to prevent damage from rotting grass and standing water.
- Lubricate all mower grease points and fill gearbox oil levels as detailed in the maintenance section.
- Tighten all bolts and pins to the recommended torque.
- Check the mower for worn and damaged parts. Perform repairs and make replacements immediately so that the mower will be ready for use at the start of the next season.
- Store the mower in a clean, dry place with the mower housing resting securely on blocks or at ground level.
- Keep the driveline yoke from sitting in water, dirt and other contaminants.
- Use spray touch-up enamel where necessary to prevent rust and maintain the appearance of the mower.



It is critical that driveline clutches slip when an obstacle or heavy load is encountered to avoid mower and/or tractor damage. If the mower sits outside for an extended period of time or is exposed to rain and/or humid air, the clutch lining plates must be inspected to ensure they are not frozen together from rust or corrosion. If the mower has been exposed to such conditions, at the start of each mowing season, and any time it is suspected that the slip clutch plates may be frozen together, readjust the slip clutch as detailed in Seasonal Clutch Maintenance of the maintenance section in this manual. *OPS-R-0032\_A*



Never allow children or other persons to ride on the Tractor or Implement. Falling off can result in serious injury or death. (SG-10)



## 14. TRANSPORTING THE TRACTOR AND IMPLEMENT

Inherent hazards of operating the tractor and implement and the possibility of accidents are not left behind when you finish working in an area. Therefore, the operator must employ good judgement and safe operation practices when transporting the tractor and implement between locations. By using good judgement and following safe transport procedures, the possibility of accidents while moving between locations can be substantially minimized. *OPS-U-0017*

# OPERATION

Before transporting the tractor and mower, idle the tractor engine, disengage the PTO and wait for all mower moving parts to come to a complete stop. Once all mower parts are completely stopped, raise the mower to transport height. **NOTE:** When raising the mower, maintain 1" clearance between the driveline and mower deck. If additional mower deck height is needed for safe transport, disconnect the driveline from the tractor and secure its end to the mower deck. The mower can then be raised to the maximum lift height. OPS-R-0033\_A



If the tractor's hydraulic pump is not independent of the tractor PTO, or if the tractor PTO has to be run to have hydraulic power, disconnect the mower driveline from the tractor PTO output shaft. Secure the driveline to the mower deck to prevent driveline damage or loss during transport. OPS-R-0034



OPERATION

## 14.1 Transporting on Public Roadways

Extreme caution should be used when transporting the tractor and implement on public roadways. The tractor must be equipped with all required safety warning features including a SMV emblem and flashing warning lights to alert drivers of the tractor's presence. Remember that roadways are primarily designed for automotive drivers and most drivers will not be looking out for you, therefore, you must look out for them. Check your side view mirrors frequently and remember that vehicles will approach quickly because of the tractor's slower speed. Be extremely cautious when the piece of equipment that you are towing is wider than the tractor tire width and/or extends beyond your lane of the road.

Make sure that a proper size safety tow chain is secured between the tractor and implement before entering a public road. OPS-U-0019



Make certain that the "Slow Moving Vehicle" (SMV) sign is installed in such a way as to be clearly visible and legible. When transporting the Equipment use the Tractor flashing warning lights and follow all local traffic regulations. (SG-6)

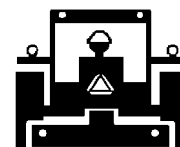

# OPERATION

## OPERATION

The SMV (Slow-Moving Vehicle) emblem is universal symbol used to alert drivers of the presence of equipment traveling on roadways at a slow speed. SMV signs are a triangular bright orange with reflective red trim for both easy day and night visibility. Make sure the SMV sign is clean and visible from the rear of the unit before transporting the tractor and implement on a public roadway. Replace the SMV emblem if faded, damaged, or no longer reflective. *OPS-U-0020*



Make sure that all tractor flashing warning lights, headlights, and brake/tail lights are functioning properly before proceeding onto public roads. While newer model tractors have plenty of lighting to provide warning signals and operating lighting, most older models are only equipped with operating lights. Consult an authorized tractor dealer for lighting kits and modifications available to upgrade the lighting on older tractor models. *OPS-U-0021*



When operating on public roads, have consideration for other road users. Pull to the side of the road occasionally to allow all following traffic to pass. Do not exceed the legal speed limit set in your country for agricultural tractors. Always stay alert when transporting the tractor and implement on public roads. Use caution and reduce speed if other vehicles or pedestrians are in the area. *OPS-U-0022*





# OPERATION

Reduce speed before turning or applying the brakes. Ensure that both brake pedals are locked together when operating on public roads. *OPS-U- 0023*



## **14.2 Hauling the Tractor and Implement**

Before transporting a loaded tractor and implement, measure the height and width dimensions and gross weight of the complete loaded unit. Ensure that the load will be in compliance with the legal limits set for the areas that will be traveled through. *OPS-U- 0024*



Use adequately sized and rated trailers and equipment to transport the tractor and implement. Consult an authorized dealer to determine the proper equipment required. Using adequately sized chains, heavy duty straps, cables and/or binders, securely tie down both the front and rear of the tractor utilizing the proper tie down locations as specified by the tractor manufacturer. *OPS-U- 0025*



# OPERATION

## OPERATION

Arrange the chains so that when tightened, the chains are pulling downward and against themselves. Carefully tighten the securing chains or other fasteners using boomers or binders to apply maximum tension. Use extreme care when attaching and removing the securing devices as the extreme tension involved when released has the potential to inflict serious injury.

While hauling the tractor and implement, make occasional stops to check that the tractor and implement have not moved or shifted and that the securing chains have maintained tension. If during transport a hard braking, sharp turning, or swerving action was performed, stop at the next safe location to inspect the security of the load. *OPS-U- 0026*



# OPERATION

## **15. TROUBLESHOOTING GUIDE**

| <b>Problem</b>       | <b>Possible Cause</b>                                     | <b>Remedy</b>  |
|----------------------|---|--|
| Not Cutting Clean    | Blades dull.  | Sharpen or replace Blades.   |
|                      | Blade rotation incorrect.                                 | Use correct Blade for Carrier.   |
|                      | Using Straight Blades                                     | Use Fan Blades in grass.   |
|                      | Carrier RPM too low.                                      | Increase PTO speed.  |
|                      | Mower not leveled.  | Adjust machine level (in very heavy weeds, 1/2" to 1" low in front).   |
|                      | Tires mashing down grass.                                 | Use offset Adapter to move Mower to the left.  |
| Breaking Blade Bolts | Ground speed too fast.                                    | Reduce ground speed.   |
|                      | Blades locked back.                                       | Free blades.   |
|                      | Blades riding up due to Blade Bolt wear.                  | Replace Blade Bolts.   |
|                      | Blades bent up.   | Replace Blades.  |
|                      | Operating with loose Blade Bolts.                         | Tighten Blade Bolts to 300 ft./lbs. (Right Hand Threads).  |
|                      | Worn Blade Bolt.  | Replace Bolt.  |
| Cutting Too High     | Blades bent up.   | Replace Blades.  |
|                      | Blade Carrier bent.                                       | Straighten or replace Blade Carrier.   |
|                      | Blades on upside down.                                    | Turn Blades right side up and tighten.   |
| Mower Vibrates       | Blade locked back.  | Loosen locked Blade.   |
|                      | Drivelines not phased.                                    | Replace Driveline.   |
|                      | Blade broken.   | Replace Blades in sets.  |
|                      | Blade Carrier bent.                                       | Repair or replace Carrier.   |
|                      | Blade Hub not properly seated on Shaft.                   | Remove Hub, check Key and Shaft, and replace or seat properly.   |
|                      | New Blade matched with worn Blade.                        | Replace Blades in sets.  |
| Mower Windrowing     | Cutting heavy material.                                   | Raise Mower and reduce ground speed.   |
| Blades Wear Fast     | Cutting in sandy or rocky conditions.<br>Blades too soft. | Increase cutting height.<br>Replace Blades with hardened, high- quality, Rhino Blades from the manufacturer. |

# OPERATION

## OPERATION

|  |  |  |
|--|--|--|
| Blade Bolts Working Loose                        | Bolts not tightened.<br>Bolt hole elongated or oversized.<br>Locknut worn out.   | Tighten Bolts to 300 ft./lbs.<br>Replace Blade Carrier.<br>Replace Locknut.  |
| Broken Cross or Cups                             | Load too high for joint.   | Use protective device with joint.<br>Check joint angles and phasing.<br>Slow down ground speed or raise Mower.   |
| End Galling of Cross and Cups                    | Speed too high.  | Reduce speed to 540 RPM.   |
| Needle Rollers Have Brinelled Into Cup and Cross | Load too high for joint.   | Check for small joint angles.<br>Use protective device.<br>Check joint angles and phasing.   |
| Shaft or Tube Twisted                            | Over-loaded.   | Replace part and then slow down ground speed or raise Mower.<br>Use protective device.<br>(See Clutch Maintenance).  |
| Tube Broken in Welded Seam                       | Over-loaded.   | Replace part.<br>(See Clutch Maintenance).   |
| Yoke Broken at Ear Tip                           | Over-loaded.   | Replace part.<br>(See Clutch Maintenance).   |
| Gearbox Noisy                                    | Improper backlash.<br>Rough gears.<br>Worn Bearing.  | Refer to Maintenance Section.<br>Run in or change Gears.<br>Replace Bearing.   |
| Slip Clutch Slipping Excessively                 | Excessive load.<br><br>Springs weak.<br>Improper adjustment.<br>Too much power for Slip Clutch.<br><br>Friction Facings worn.<br>Oil on Facings.<br>Friction Facings glazed. | Reduce ground speed and/or raise Mower.<br>Replace Springs.<br>Re-adjust Slip Clutch.<br>Reduce ground speed and material intake.<br>Replace Facings.<br>Replace Facings.<br>Clean with emery cloth. |
| Oil Blowing out Vent Plug                        | Flat bottomed Vent Plug or shallow cavity Plug.<br><br>Oil level too high.   | Replace with proper Vent Plug, Cavity in Oil Plug should be approximately 5/8"<br>Lower oil level to Plug.   |

# OPERATION

|   |   |   |
|---|---|---|
| Gearbox Leaking   | Damaged Oil Seal.<br>No Oil Seal.<br>Oil too light.<br>Bent Shaft.<br>Oil Seal Race rough.<br>Oil Seal installed wrong.<br>Oil Seal not sealing in the housing.<br><br>Bearings loose.<br>Vent Plug stopped up.<br>Oil level too high.<br>Gasket damaged.<br>Bolts loose. | Replace Seal.<br>Install Oil Seal.<br>Use EP140.<br>Replace Oil Seal and Shaft.<br>Replace Shaft or repair Race.<br>Replace Seal.<br>Replace Seal or use a sealant on O.D. of Seal.<br>Adjust Bearings.<br>Open Vent Plug.<br>Drain oil to proper level.<br>Replace Gasket.<br>Tighten Bolts. |
| Driveline Integral Shields Rattling or Not Turning Freely | Integral Shields deformed.<br>Nylon Bearing worn.   | Replace Shield.<br>Replace Nylon Bearing.   |
| Rapid Clevis Wear   | Washer not used.  | Install washers above and below drawbar.  |
| Clevis Bending or Spreading Open.                         | Using Pin or Bolt not tightened.  | Use 1" grade 5 or 8 Bolt & tighten Nut.   |



# **MAINTENANCE SECTION**

Maintenance Section 5-1

# MAINTENANCE

Before operating your Rotary Cutter, make sure it is properly lubricated and thoroughly inspected. Only a minimum of time and effort is required to regularly lubricate and maintain this machine to provide long life and trouble free operation.



Always disengage the PTO before raising the Rotary Cutter for transporting or making adjustments.

**MAINTENANCE**

## Lubrication

Do not let excess grease collect on or around parts, particularly when operating in sandy areas. The illustrations below shows lubrication points. The chart gives the frequency of lubrication in hours, based on normal operating conditions. Severe or unusual conditions may require more frequent lubrication (**Figure Mnt-0009**).

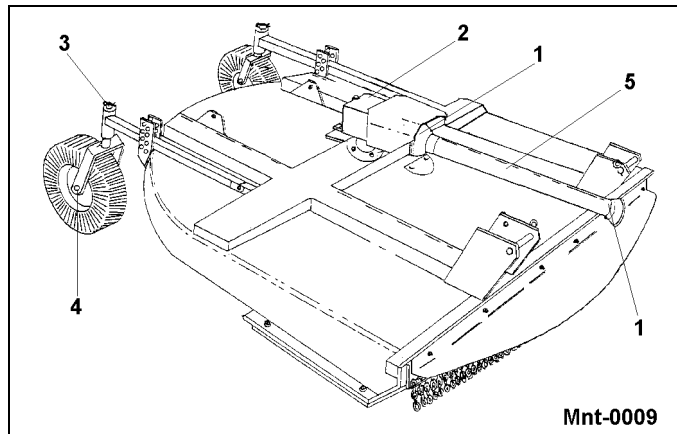

Mnt-0009

Use an SAE multi-purpose, lithium-type grease for all locations shown. Be sure to clean the fitting thoroughly before using grease gun. Daily lubrication of the wing driveline slip joint is necessary. Failure to maintain proper lubrication will result in damage to U-joints, gearbox, and/or driveshaft.

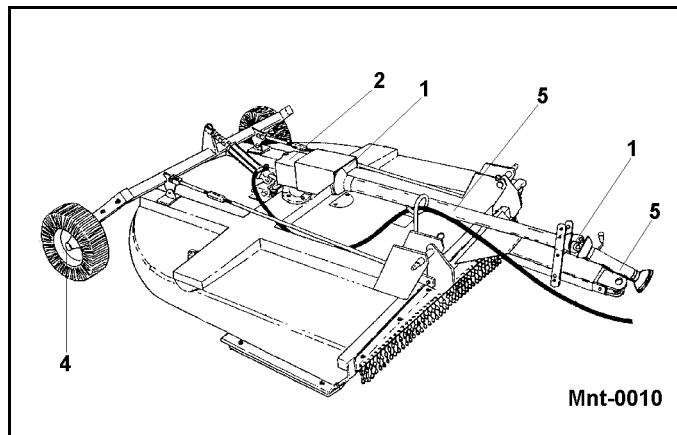

Mnt-0010

### Lubrication Fitting Location

| ITEM | DESCRIPTION      | FREQUENCY   |
|------|------------------|-------------|
| 1.   | U-Joints         | 8 hours     |
| 2.   | Gearbox          | Check Daily |
| 3.   | Tail Wheel Pivot | 10 hours    |
| 4.   | Wheel Hubs       | Weekly      |
| 5.   | Telescoping      | 8 hours     |



# MAINTENANCE

## Gearbox Lubrication

The Gearbox has been filled with lubricant to the Test Plug Level prior to shipment. However, you should check the oil level at Test Plug before operating, and frequently thereafter.

The gearbox should not require additional lubricant unless the box is cracked or a seal is leaking. It is recommended that the oil level plug be removed after every 8 to 10 hours of operation and oil added until it runs out Test Plug hole. The Test Plug is located on the rear of the Gearbox. Filler Plug is located on top of Gearbox (**Figure Mnt-0011**).

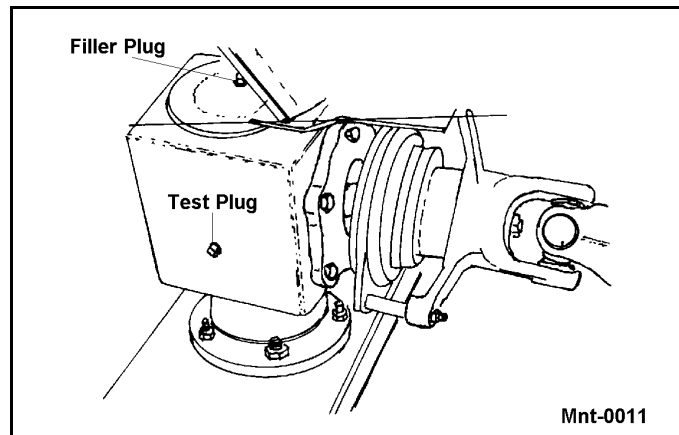

**NOTE:** Overfilling the Gearbox will cause pressure to build up and cause Oil Seals to leak.

**ATTENTION:** If the Gearbox suddenly starts making an unusual noise, stop at once, check for leaks, and refill Gearbox as required.

## Tail Wheel Lubrication

Tail Wheel Bearings are packed at the factory with heavy-duty bearing grease. Grease Fittings are provided in the Wheel Hub and Tail Wheel Beam. Grease after 10 hours of use (**Figure Mnt-0004**).

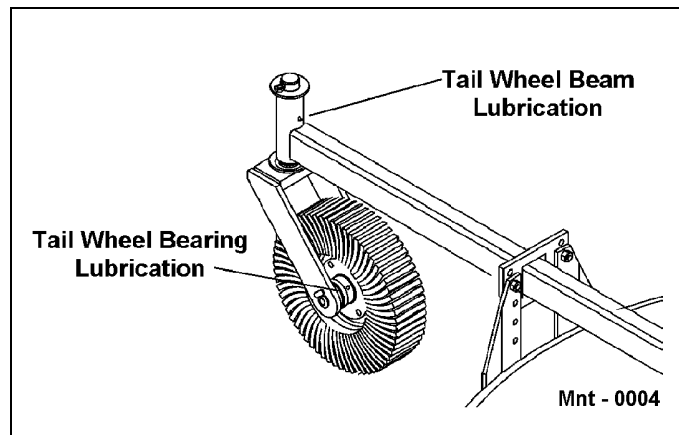

Recommended lubricant is SAE EP85W14QT with EP additives for extreme pressure and temperature, with a APL-GI-5 Service rating. This lube also has tack agent added so oil sticks to parts when box is not running. Gearbox capacity is 2 Quarts.

# MAINTENANCE

## Driveline Lubrication

Grease Fittings are located on the Cross Assembly of each U-Joint and on the telescoping tubes. Grease the U-Joint after each 8 hours of use. Do not force grease through the Needle Cup Assemblies. Grease the telescoping tubes after every 8 hours use. Some PTO-to-Hitch connections may necessitate cutting a hole in the shields to be able to align the Grease Fitting holes for lubrication. Lubricate the shield bearings every 16 hours (**Figure Mnt-0012**).

MAINTENANCE

## Driveline Shield - Pull-Type

The Driveline Integral Shields should not become dented or otherwise damaged. The Integral Shield Assembly has a Nylon Bearing at each end and should turn freely (**Figure Mnt-0012**). This nylon bearing should require lubrication every 8 hours. To remove the Integral Shields for replacement or repair, turn the three Nylon Nuts 1/4 turn in the Shield Slots of the Cone and Tube and remove them. Slip the Shield Cone Assembly off inner section of the Driveline. Install the new or repaired Shield on the Driveline. Place the split Nylon Bearing over the Driveline Housing of Shaft against the Yoke and in the Bearing groove. Install shield over the Housing so the Nylon Bearing fits into the Shield Bearing Retainer. Align a slot in the Shield Cone with one of the slots in the Shield. Put one of the Nylon Nuts back in through the aligned slots and turn until it is perpendicular to the slots. Add the other two Nylon Nuts.

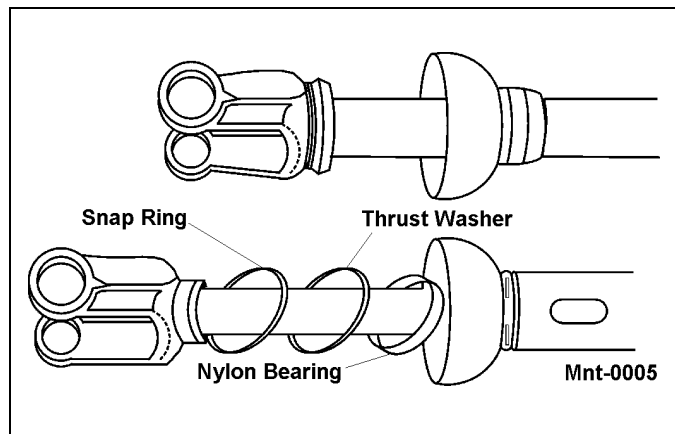

Make certain that the Driveline Integral Shields are free to telescope and rotate around the Driveline without binding.

# MAINTENANCE

MAINTENANCE

## Protective, Integral Shields - Lift-Type

Protective Driveline Shields should be installed on Drivelines as shown in **Figure Mnt-0013** below. The protective Integral Shields are assembled onto nylon bearings and should turn freely - but should not spin. Greasing the nylon bearings is not required but will not harm them. Each Shield Bearing is composed of two nylon bearing halves. They may be removed by prying the locking lug of the nylon bearing out of the slot in the Shield and pulling the bearing out through the slot. To replace the nylon bearings, align the slot in the shield over the groove in the Yoke of the Driveline. Insert the beveled tip of the nylon bearing into the slot of the shield and push into place. Push the locking lug of the nylon bearing into the slot until it snaps into place.



Driveline Integral Shields must be in place at all times when operating.

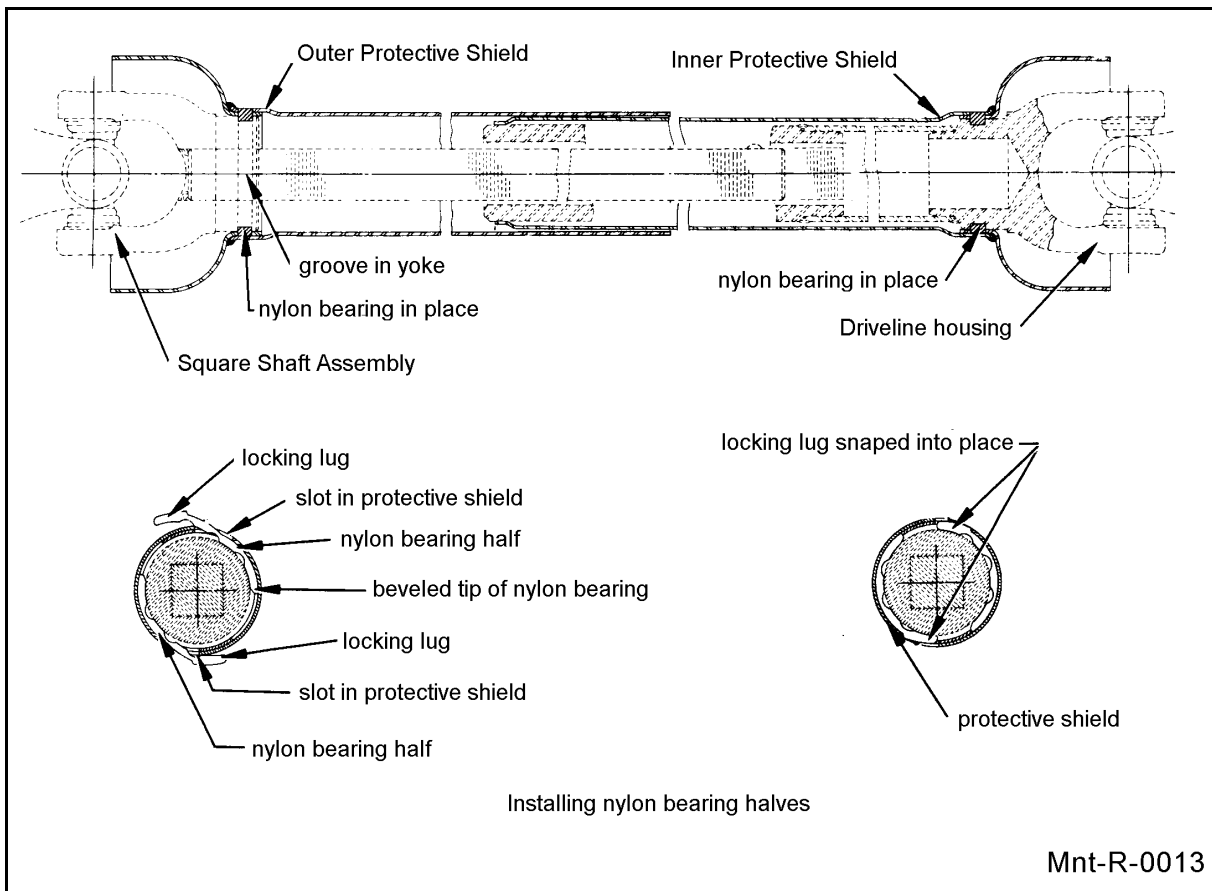

# MAINTENANCE

MAINTENANCE

## Slip Clutch

Avoid overheating of the Slip Clutch by too long or too frequent slipping, as this can damage the friction plates and limiter parts. When checking Slip Clutch for overheating, DO NOT touch with hand. Slip Clutch could be extremely hot and cause severe burn.

If an adjustment is required, this may be done in the field by following the procedure outlined below. Following these instructions will give maximum rated torque and long life (**Figure Mnt-0006**).

1. With the three Capscrews (8) backed out until the points are below the surface of the circular Adjusting Nut (7), run Adjusting Nut up finger-tight, or slightly less than finger-tight.
2. Alternately tighten the hardened, cup point Capscrews (8) no more than one-half turn at a time until the Capscrew heads "Bottom Out". Do not over tighten the Capscrews nor completely flatten the Spring Washers (5).

If the Hub is removed from the Shaft for any reason, the Shaft and Hub should be coated with a heavy grease before reassembly to prevent Hub from freezing to Shaft.

## Seasonal Slip Clutch Maintenance

It is important that the slip clutch slips when an obstacle or load heavier than the setting is encountered. Before using the cutter each season, use the following procedure to make sure the slip clutch will slip and give the overload protection required.

1. Loosen Bolts (8) until gap between adjusting nut (7) and guide ring is approximately 1/16".
2. Attach machine to tractor, set engine at approximately half throttle and quickly engage PTO. This procedure will break slip clutch facings loose and allow the proper torque to be maintained.
3. Return the bolts to their original position as described above.

**NOTE:** If machine sits outside longer than 30 days and is exposed to rain and humid air, the clutches should be removed from machine and stored in a dry area. Slip Clutch facings will soak up moisture and cause the metal plates to rust badly. When this occurs, the break-away torque increases greatly and damage to gearbox, driveline, or tractor PTO can occur.

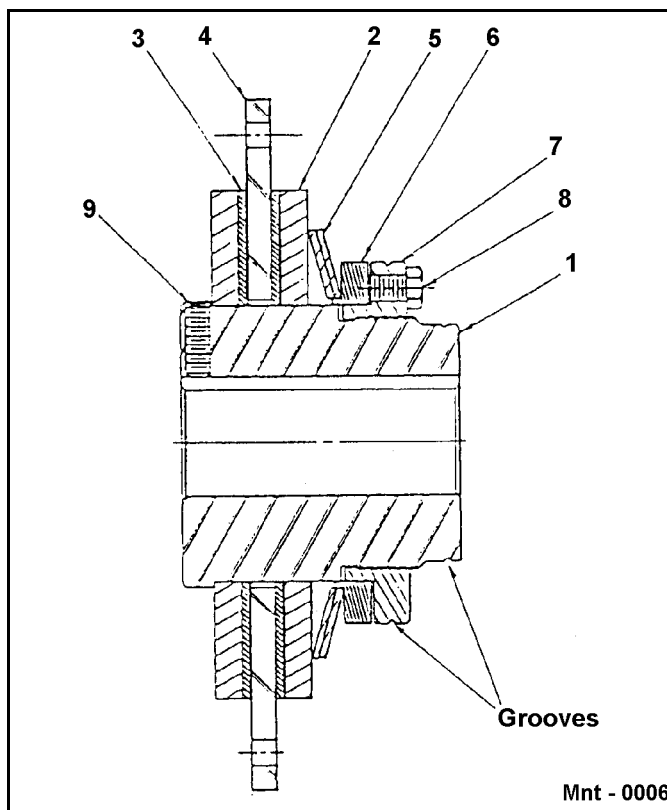

### **WARNING**

When attaching PTO yoke to tractor PTO shaft, it is important that spring-activated locking collar slides freely and locking balls are seated in groove on PTO shaft. A loose shaft could slip off and result in personal injury or damage to cutter.

# MAINTENANCE

## Blade Servicing

Inspect blades before each use to determine that they are properly installed and in good condition. Replace any blade that is bent, excessively nicked, worn, or has any other damage. Small nicks can be ground out when sharpening.

### Important

When sharpening blades, grind each blade the same amount to maintain balance. The difference in blade weights should not exceed 1 ounce. Unbalanced blades will cause excessive vibration which can damage gear box bearings. Vibration may also cause structural cracks in cutter housing.

### WARNING

Use only original equipment blades on this cutter. They are made of special heat-treated alloy steel. Substitute blades may not meet specifications and may fail in a hazardous manner that could cause injury.

## Blade Sharpening

Always sharpen both blades at same time to maintain balance. Follow original sharpening pattern as shown in **Figure Mnt-0008**. Always sharpen blades by grinding. DO NOT heat and pound out edge. Do not sharpen blade to a razor edge, but leave a 1/16" blunt edge. Do not sharpen back side of blade.

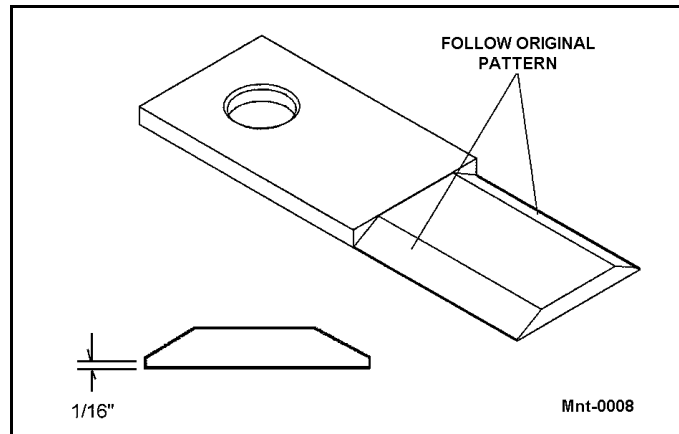

### WARNING

Avoid personal injury. Always block the cutter up to prevent it from falling when the blades and or carrier are being serviced.

### DANGER

Replace bent or broken blades with new blades. NEVER ATTEMPT TO STRAIGHTEN, WELD, OR WELD HARDFACING ON BLADES SINCE THIS WILL LIKELY CRACK OR OTHERWISE DAMAGE THE BLADE WITH SUBSEQUENT FAILURE AND POSSIBLE SERIOUS INJURY FROM THROWN BLADES. (SGM-10)

# MAINTENANCE

## Blade Removal

To remove blades for sharpening or replacement, remove the cover plate on deck of cutter near gear box. Remove lock nut from blade bolt. **NOTE:** *Inspect lock nut after removal and replace if threads are damaged.* Always replace nut when replacing blade bolt. When installing blades be sure and check blade bolt pivot diameter for wear. Replace bolt if worn more than 1/4 inch at any point. Install blade bolts with partially worn side of bolt either toward or away from center. Tighten lock nut to 350 ft. lbs.



### WARNING

Avoid personal injury. Blade and/or blade carrier removal should be done only with the tractor engine shut off, key removed, in neutral, parking brake on, and PTO disengaged and the cutter blocked in the raised position.

## Blade Carrier Removal

Remove cotter pin and loosen slotted nut on gearbox shaft. Loosen but do not remove the nut until the blade carrier is loosened. Use a suitable 2 jaw gear puller to pull carrier off tapered gearbox shaft. If gear puller is not available use long bar inserted through blade bolt access hole with end against rotor bar. Strike opposite end of bar with sledge hammer. Rotate blade carrier 180 degrees and repeat process.

## Blade Carrier Installation

Clean the hub on the blade carrier and the output shaft on the gearbox. Position carrier on the gearbox output shaft and install hardened washer, slatted nut, and cotter pin.

Tighten nut holding blade carrier to minimum 450 ft. pounds, strike the carrier near the hub several times with a heavy hammer to seat the hub. Use a suitable spacer over the nut to prevent damage to the nut and threads. Retighten the nut to 450 ft. pounds. Install cotter pin and spread.

### Important

Always recheck gearbox output shaft slotted blade carrier retaining nut torque after a few hours operation.



### WARNING

Avoid personal injury. Do not work under cutter without support blocks to keep frame from falling.

# MAINTENANCE

## Storage

Your rotary cutter represents an investment from which you should get the greatest possible benefit. Therefore, when the season is over, the cutter should be thoroughly checked and prepared for storage so that a minimum amount of work will be required to put it back into operation for the next season. The following are suggested storage procedures:

1. Thoroughly clean the cutter.
2. Lubricate the cutter as covered in Maintenance Section.
3. Tighten all bolts and pins to the recommended torque.
4. Check the cutter for worn or damaged parts. Make replacements immediately.
5. Store the cutter in a clean, dry place with the cutter housing resting on blocks.
6. Use spray touch-up enamel where necessary to prevent rust and maintain the appearance of the cutter.



## Proper Torque For Fasteners

The chart lists the correct tightening torque for fasteners. When bolts are to be tightened or replaced, refer to this chart to determine the grade of bolts and the proper torque except when specific torque values are assigned in manual text.





Recommended Torque in Foot Pounds Unless Otherwise Stated in the Manual\*

**NOTE:** These values apply to fasteners as received from supplier, dry or when lubricated with normal engine oil. They do not apply if special graphited or molydisulphide greases or other extreme pressure lubricants are used. This applies to both UNF fine and UNC coarse threads.

Proper Torque values for bolts that are measured in Inches

| Bolt Diameter |  |  |  |
|---------------|---|---|---|
|               | Head Marking<br>No Marks<br>Grade Two<br>Pound - Foot Value<br>Dry                  | Head Marking<br>Three Lines<br>Grade Five<br>Pound - Foot Value<br>Dry              | Head Marking<br>Six Lines<br>Grade Eight<br>Pound - Foot Value<br>Dry               |
| 1/4"          | 5.5   | 9   | 12.5  |
| 5/16"         | 11  | 18  | 26  |
| 3/8"          | 20  | 33  | 46  |
| 7/16"         | 32  | 52  | 75  |
| 1/2"          | 60  | 80  | 116   |
| 9/16"         | 70  | 115   | 160   |
| 5/8"          | 100   | 160   | 225   |
| 3/4"          | 175   | 280   | 400   |
| 7/8"          | 175   | 450   | 650   |
| 1"            | 270   | 675   | 975   |
| 1-1/8"        | 375   | 850   | 1350  |
| 1-1/4"        | 530   | 1200  | 1950  |
| 1-3/8"        | 700   | 1550  | 2550  |
| 1-1/2"        | 930   | 2100  | 3350  |

Proper Torque values for Metric bolts

| Bolt Diameter |  |  |  |  |
|---------------|---|---|---|---|
|               | Head Marking<br>4.8<br>Pound - Foot Value<br>Dry                                    | Head Marking<br>8.8 or 9.8<br>Pound - Foot Value<br>Dry                               | Head Marking<br>10.9<br>Pound - Foot Value<br>Dry                                     | Head Marking<br>12.9<br>Pound - Foot Value<br>Dry                                     |
| 6mm           | 4.5   | 8.5   | 12  | 14.5  |
| 8mm           | 11  | 20  | 30  | 35  |
| 10mm          | 21  | 40  | 60  | 70  |
| 12mm          | 37  | 70  | 105   | 120   |
| 14mm          | 60  | 110   | 165   | 190   |
| 16mm          | 92  | 175   | 265   | 300   |
| 18mm          | 125   | 250   | 350   | 410   |
| 20mm          | 180   | 350   | 500   | 580   |
| 22mm          | 250   | 475   | 675   | 800   |
| 24mm          | 310   | 600   | 850   | 1000  |
| 27mm          | 460   | 875   | 1250  | 1500  |
| 30mm          | 625   | 1200  | 1700  | 2000  |

\*To get Newton-Meters multiply pound-foot of torque by 1.356

# RHINO

## LIMITED WARRANTY

### 1. LIMITED WARRANTIES

- 1.01. Rhino warrants for one year from the purchase date to the original non-commercial, governmental, or municipal purchaser ("Purchaser") and warrants for six months to the original commercial or industrial purchaser ("Purchaser") that the goods purchased are free from defects in material or workmanship.
- 1.02. Manufacturer will replace for the Purchaser any part or parts found, upon examination at one of its factories, to be defective under normal use and service due to defects in material or workmanship.
- 1.03. This limited warranty does not apply to any part of the goods which has been subjected to improper or abnormal use, negligence, alteration, modification, or accident, damaged due to lack of maintenance or use of wrong fuel, oil, or lubricants, or which has served its normal life. This limited warranty does not apply to any part of any internal combustion engine, or expendable items such as blades, shields, guards, or pneumatic tires except as specifically found in your Operator's Manual.
- 1.04. Except as provided herein, no employee, agent, Dealer, or other person is authorized to give any warranties of any nature on behalf of Manufacturer.

### 2. REMEDIES AND PROCEDURES.

- 2.01. This limited warranty is not effective unless the Purchaser returns the Registration and Warranty Form to Manufacturer within 30 days of purchase.
- 2.02. Purchaser claims must be made in writing to the Authorized Dealer ("Dealer") from whom Purchaser purchased the goods or an approved Authorized Dealer ("Dealer") within 30 days after Purchaser learns of the facts on which the claim is based.
- 2.03. Purchaser is responsible for returning the goods in question to the Dealer.
- 2.04. If after examining the goods and/or parts in question, Manufacturer finds them to be defective under normal use and service due to defects in material or workmanship, Manufacturer will:
  - (a) Repair or replace the defective goods or part(s) or
  - (b) Reimburse Purchaser for the cost of the part(s) and reasonable labor charges (as determined by Manufacturer) if Purchaser paid for the repair and/or replacement prior to the final determination of applicability of the warranty by Manufacturer.

The choice of remedy shall belong to Manufacturer.

- 2.05. Purchaser is responsible for any labor charges exceeding a reasonable amount as determined by Manufacturer and for returning the goods to the Dealer, whether or not the claim is approved. Purchaser is responsible for the transportation cost for the goods or part(s) from the Dealer to the designated factory.

### 3. LIMITATION OF LIABILITY.

- 3.01. MANUFACTURER DISCLAIMS ANY EXPRESS (EXCEPT AS SET FORTH HEREIN) AND IMPLIED WARRANTIES WITH RESPECT TO THE GOODS INCLUDING, BUT NOT LIMITED TO, MERCHANTABILITY AND FITNESS FOR A PARTICULAR PURPOSE.
- 3.02. MANUFACTURER MAKES NO WARRANTY AS TO THE DESIGN, CAPABILITY, CAPACITY, OR SUITABILITY FOR USE OF THE GOODS.
- 3.03. EXCEPT AS PROVIDED HEREIN, MANUFACTURER SHALL HAVE NO LIABILITY OR RESPONSIBILITY TO PURCHASER OR ANY OTHER PERSON OR ENTITY WITH RESPECT TO ANY LIABILITY, LOSS, OR DAMAGE CAUSED OR ALLEGED TO BE CAUSED DIRECTLY OR INDIRECTLY BY THE GOODS INCLUDING, BUT NOT LIMITED TO, ANY INDIRECT, SPECIAL, CONSEQUENTIAL, OR INCIDENTAL DAMAGES RESULTING FROM THE USE OR OPERATION OF THE GOODS OR ANY BREACH OF THIS WARRANTY. NOT WITHSTANDING THE ABOVE LIMITATIONS AND WARRANTIES, MANUFACTURER'S LIABILITY HEREUNDER FOR DAMAGES INCURRED BY PURCHASER OR OTHERS SHALL NOT EXCEED THE PRICE OF THE GOODS.
- 3.04. NO ACTION ARISING OUT OF ANY CLAIMED BREACH OF THIS WARRANTY OR TRANSACTIONS UNDER THIS WARRANTY MAY BE BROUGHT MORE THAN TWO (2) YEARS AFTER THE CAUSE OF ACTION HAS OCCURRED.

### 4. MISCELLANEOUS.

- 4.01. Proper Venue for any lawsuits arising from or related to this limited warranty shall be only in Guadalupe County, Texas.
- 4.02. Manufacturer may waive compliance with any of the terms of this limited warranty, but no waiver of any terms shall be deemed to be a waiver of any other term.
- 4.03. If any provision of this limited warranty shall violate any applicable law and is held to be unenforceable, then the invalidity of such provision shall not invalidate any other provisions herein.
- 4.04. Applicable law may provide rights and benefits to purchaser in addition to those provided herein.

KEEP FOR YOUR RECORDS

ATTENTION: Purchaser should fill in the blanks below for his reference when buying repair parts and/or for proper machine identification when applying for warranty.

Rhino Implement Model \_\_\_\_\_ Serial Number \_\_\_\_\_

Date \_\_\_\_\_ Purchased \_\_\_\_\_  
Dealer \_\_\_\_\_

ATTENTION:

READ YOUR OPERATOR'S MANUAL

**RHINO®**

1020 S Sangamon Ave.

Gibson City, IL 60936

800-446-5158

Email: [parts@servis-rhino.com](mailto:parts@servis-rhino.com)







## TO THE OWNER/OPERATOR/DEALER

In addition to the standard Limited Warranty shown on the facing page, Servis-Rhino also provides:

- 1.) ONE-YEAR (12 months) {or 6 month for Commercial/Industrial Users} LIMITED WARRANTY on the **DRIVELINE components** provided they have been properly maintained† and have not been subjected to abuse or mis-use.
- 2.) FIVE-YEAR (60 months) LIMITED WARRANTY\* on **GEARBOX components** provided they have been properly maintained† and have not been subjected to abuse or mis-use except as limited below.

\* WARRANTY LIMITATIONS - GEARBOX

A) Warranty is ONE-YEAR (12 MONTHS) for Seals (After one year, seals are considered to be WEARING PARTS and replacement is the users' responsibility.)

B) Users' Gearboxes may be rebuilt by Servis-Rhino or replaced by new or rebuilt Gearboxes at the option of Servis-Rhino.

† NOTE - "properly maintained" specifically includes, but is not limited to:

A) Running Gearboxes with the proper amount of the correct lubricant.

B) Adjusting Slip Clutches correctly to provide proper protection for Driveline and Gearbox Components.

---

To keep your implement running efficiently and safely, read your manual thoroughly and follow these directions and the Safety Messages in this Manual. The Table of Contents clearly identifies each section where you can easily find the information you need.

The OCCUPATIONAL SAFETY AND HEALTH ACT (1928.51 Subpart C) makes these minimum safety requirements of tractor operators:

REQUIRED OF THE OWNER:

1. Provide a Roll-Over-Protective Structure that meets the requirements of this Standard; and
2. Provide Seatbelts that meet the requirements of this paragraph of this Standard and SAE J4C; and
3. Ensure that each employee uses such Seatbelt while the tractor is moving; and
4. Ensure that each employee tightens the Seatbelt sufficiently to confine the employee to the protected area provided by the ROPS.

REQUIRED OF THE OPERATOR:

1. Securely fasten seatbelt if the tractor has a ROPS.
2. Where possible, avoid operating the tractor near ditches, embankments, and holes.
3. Reduce speed when turning, crossing slopes, and on rough, slick, or muddy surfaces.
4. Stay off slopes too steep for safe operation.
5. Watch where you are going - especially at row ends, on roads, and around trees.
6. Do not permit others to ride.
7. Operate the tractor smoothly - no jerky turns, starts, or stops.
8. Hitch only to the drawbar and hitch points recommended by the tractor manufacturer.
- 9.z When the tractor is stopped, set brakes securely and use park lock, if available.



**CY84**  
**ROTARY CUTTER**

---

CY84-SOM-03/08  
Printed U.S.A

P/N 00771528C